



Question: 4/15

STUDY GROUP 15 - CONTRIBUTION 134

SOURCE*: EDITOR RECOMMENDATION G.994.1

TITLE: DRAFT NEW RECOMMENDATION G.994.1 - HANDSHAKE PROCEDURES
FOR DIGITAL SUBSCRIBER LINE (DSL) TRANSCEIVERS - FOR APPROVAL

RECOMMENDATION G.994.1

**HANDSHAKE PROCEDURES FOR DIGITAL SUBSCRIBER
LINE (DSL) TRANSCEIVERS**

Summary

Recommendation G.994.1 provides a flexible mechanism for Digital Subscriber Line (DSL) transceivers to exchange capabilities and to select a common mode of operation. It includes parameters relating to service and application requirements as well as parameters pertinent to various DSL transceivers. G.994.1 is currently an integral part of the start-up procedure for both G.992.1 and G.992.2. It is anticipated that future DSL Recommendations will also be able to make use of G.994.1. Provisions are also included for exchanging non-standard information.

1 Scope

This Recommendation defines signals, messages and procedures for exchanging these between Digital Subscriber Line (DSL) equipment, when the modes of operation of the equipment need to be automatically established and selected, but before signals are exchanged which are specific to a particular DSL Recommendation.

For interrelationships of this Recommendation with other G.99x-series Recommendations, see Recommendation G.995.1 (informative).

* **Contact:** Les Brown
Motorola
400 Matheson Blvd. W
Mississauga, Ontario
Canada

Tel: +1 905 507 7361
Fax: +1 905 507 7236
Email: llb005@email.mot.com

The principal characteristics of this Recommendation are as follows:

- a) use over metallic local loops;
- b) provisions to exchange capabilities information between DSL equipment for identifying common modes of operation;
- c) provisions for DSL equipment at either end of the loop to select a common mode of operation or to request the other end to select the mode;
- d) provisions for exchanging non-standard information between DSL equipment;
- e) provisions to exchange and request service and application related information;
- f) support for both duplex and half-duplex transmission modes.

2 References

The following ITU-T Recommendations and other references contain provisions, which, through reference in this text, constitute provisions of this Recommendation. At the time of publication, the editions indicated were valid. All Recommendations and other referenced standards are subject to revision; all users of this Recommendation are therefore encouraged to investigate the possibility of applying the most recent editions of the Recommendations and other references listed below. A list of currently valid ITU-T Recommendations is regularly published.

ISO/IEC 3309 - 1993 - Information Technology - Telecommunications and information exchange between systems - High-level data link control (HDLC) procedures - frame structure.

ITU-T Recommendation T.35 - 1999 - Procedure for the allocation of CCITT defined codes for non-standard facilities.

ITU-T Recommendation G.992.1 - 1999 - Asymmetrical Digital Subscriber Line (ADSL) Transceivers.

ITU-T Recommendation G.992.2 - 1999 - Splitterless asymmetrical Digital Subscriber Line (ADSL) Transceivers.

ITU-T Recommendation G.997.1 - 1999 - Physical layer management for Digital Subscriber Line (DSL) Transceivers.

3 Definitions

For the purposes of this Recommendation, the following definitions apply:

3.1 carrier set:

A set of one or more frequencies associated with the PSD mask of a particular xDSL Recommendation.

3.2 downstream:

The direction of transmission from the xTU-C to the xTU-R.

3.3 errored frame:

A frame that contains a frame check sequence (FCS) error.

3.4 Galf:

An octet of value 81_{16} ; i.e. the ones complement of an HDLC flag.

3.5 initiating signal:

A signal that initiates the start-up procedure of a G.994.1 session.

3.6 initiating station:

The station that initiates the start-up procedure of a G.994.1 session.

3.7 invalid frame:

A frame that has fewer than four octets between flags, excluding transparency octets.

3.8 message:

Framed information conveyed via modulated transmission.

3.9 responding signal:

A signal that is sent in response to an initiating signal.

3.10 responding station:

The station that responds to the initiation of the start-up procedure of a G.994.1 session.

3.11 session:

A G.994.1 session comprises a start-up procedure, one or more transactions, and a clear-down procedure (except as noted in § 12).

3.12 signalling family:

A group of carrier sets which are integral multiples of a given carrier spacing frequency.

3.13 transaction:

A sequence of G.994.1 messages, ending with either a positive acknowledgement [ACK(1) (except as noted in § 7.5)], a negative acknowledgement (NAK), or a time-out (see § 12).

3.14 upstream:

The direction of transmission from the xTU-R to the xTU-C.

4 Abbreviations

For the purposes of this Recommendation, the following abbreviations are used:

ACK	Acknowledge Message
ADSL	Asymmetric Digital Subscriber Line
CL	Capabilities List
CLR	Capabilities List Request
FCS	Frame Check Sequence
HSTU	Handshake Transceiver Unit
ISO	International Organization for Standardization
ITU-T	International Telecommunication Union - Telecommunication Standardization Sector
LSB	Least Significant Bit
MR	Mode Request Message
MS	Mode Select Message
MSB	Most Significant Bit
NAK	Negative Acknowledge Message
PSTN	Public Switched Telephone Network
REQ	Request Message Type Message
xDSL	Any of the various types of Digital Subscriber Lines (DSL)
xTU-C	xDSL central site terminal unit
xTU-R	xDSL remote terminal unit

5 System reference diagram

Figure 1/G.994.1 illustrates the system reference model for this Recommendation.

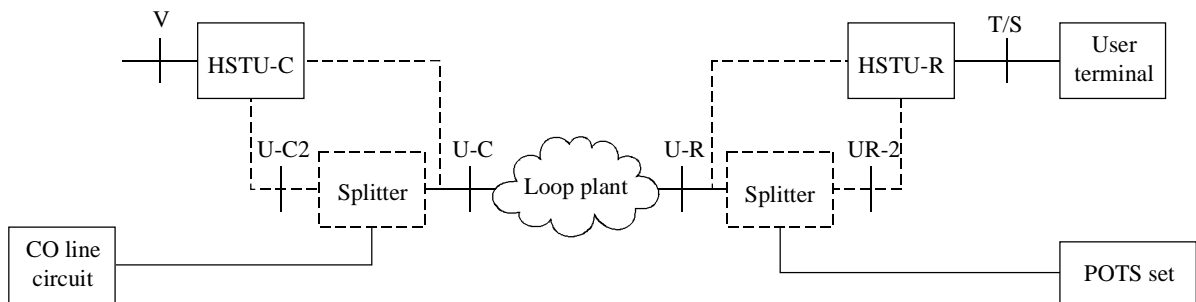

T1531730-99

FIGURE 1/G.994.1
System reference model

The system reference model identifies the necessary functional blocks and the reference points and/or interface points that may be used or have implications in this Recommendation.

The system reference model comprises the following blocks:

- transceivers; HSTU-C and HSTU-R;
- splitter function;
- loop plant;
- user terminal;
- POTS set;
- CO line circuit.

This Recommendation defines the signals, messages and procedures for common mode selection, and as such only relates to the functions associated with the HSTU-C and HSTU-R blocks. HSTU is used to signify that the signals, messages and procedures defined in this Recommendation are different from the G.99x Recommendations that use this Recommendation as a common start-up procedure. The remaining blocks are included to illustrate a reference system.

Splitters may or may not be present at the central and remote sites and are therefore signified by dotted boxes. If splitters are present, the HSTU-C (HSTU-R) may be connected to either or both the U-C (U-R) and U-C2 (U-R2) interface points, signified by the dotted connecting lines.

The reference points V, U, T/S may not need to be exposed. This system reference model does not imply any particular implementation of the signals, messages and procedures defined in the Recommendation.

The HSTU negotiates modes of operation on behalf of one or more xDSL terminal units that are hereafter referred to as xTU.

6 Signals and modulation

6.1 Description of signals

The signalling families used in G.994.1, and the carrier sets defined within each family, are described in this clause.

Each xDSL mode of operation has a mandatory carrier set associated with it. For each xDSL mode of operation implemented by a G.994.1 station, the initial G.994.1 transmission from the station shall include the associated mandatory carrier set for that mode.

NOTE - In the interest of explicitly indicating the presence of HSTU-x which might not have common modes, the initial transmission should use as many carriers as possible and HSTU-x are encouraged to detect all carriers from all signalling families.

Both duplex and half-duplex transmission modes are defined for use within G.994.1. The transmission mode supported is a function of carrier set and is specified in Table 1/G.994.1 and Table 3/G.994.1.

Frequencies other than those specified in Table 1/G.994.1 and Table 3/G.994.1 shall not be transmitted simultaneously with G.994.1 signals.

The tolerance of the symbol rate and carrier frequencies for an HSTU-C shall be ± 50 ppm. The tolerance of the symbol rate and carrier frequencies for an HSTU-R shall be ± 200 ppm during R-TONES-REQ and ± 50 ppm during and after R-TONE1 (in duplex transmission mode) or

R-FLAG1 (in half-duplex transmission mode). The HSTU-R may perform partial or full loop timing acquisition during the silence period preceding R-TONE1 or R-FLAG1. For both the HSTU-C and HSTU-R transmitter, the symbol rate and carrier frequencies shall be time locked.

NOTE - National regulations may limit signal transmission to those carriers that fall within the PSD mask of the xDSL mode(s) supported by the station.

NOTE - It is advised to monitor for existing services prior to transmitting signals to avoid interfering with them.

NOTE - New xDSL services that wish to use G.994.1 are strongly encouraged to use currently defined carrier sets rather than defining new carrier sets.

6.1.1 4.3125 kHz signalling family

Carrier frequencies within this signalling family are given by $N * 4.3125$ kHz, where N is a positive integer. The symbol rate shall be $4312.5/8 \equiv 539.0625$ symbols per second.

Within this family, there are three upstream carrier sets, designated A43, B43, and C43. Each upstream carrier set has an associated downstream carrier set that carries the same designation. The carrier set frequencies and the maximum transmit power level per carrier for each carrier set are defined in Table 1/G.994.1, where frequency = $N \times 4.3125$ kHz.

TABLE 1/G.994.1

Carrier sets for the 4.3125 kHz signalling family

Carrier set designation	Upstream carrier sets		Downstream carrier sets		Transmission mode
	Frequency indices (N)	Maximum power level/carrier (dBm)	Frequency indices (N)	Maximum power level/carrier (dBm)	
A43	9 17 25	-1.65	40 56 64	-3.65	duplex only
B43	37 45 53	-1.65	72 88 96	-3.65	duplex only
C43	7 9	-1.65	12 14 64	-3.65	duplex only

The carrier sets in this family are mandatory for the xDSL modes listed in Table 2/G.994.1. One or more carriers listed in Table 1/G.994.1 or Table 3/G.994.1 may be transmitted in addition to the mandatory carrier set listed in Table 2/G.994.1. Carriers not listed in Table 1/G.994.1 or Table 3/G.994.1 shall not be transmitted.

TABLE 2/G.994.1

Mandatory carrier sets

xDSL Recommendation(s)	Carrier set designation
G.992.1 - Annex A, G.992.2 - Annex A/B	A43
G.992.1 - Annex B	B43
G.992.1 - Annex C, G.992.2 - Annex C	C43

6.1.2 4 kHz signalling family

Carrier frequencies within this signalling family are given by $N * 4$ kHz, where N is a positive integer. The symbol rate shall be $4000/5 \equiv 800$ symbols per second.

Within this family, there is one upstream carrier set, designated A4. The associated downstream carrier set has the same designation. The carrier frequencies and the maximum transmit power level per carrier are defined in Table 3/G.994.1, where frequency = $N \times 4$ kHz.

TABLE 3/G.994.1

Carrier sets for the 4 kHz signalling family

Carrier set designation	Upstream carrier sets		Downstream carrier sets		Transmission mode
	Frequency indices (N)	Maximum power level/carrier (dBm)	Frequency indices (N)	Maximum power level/carrier (dBm)	
A4	3	for further study	5	for further study	half-duplex only

The carrier sets in this family are mandatory for the xDSL modes listed in Table 4/G.994.1. One or more carriers listed in Table 1/G.994.1 or Table 3/G.994.1 may be transmitted in addition to the mandatory carrier set listed in Table 4/G.994.1. Carriers not listed in Table 1/G.994.1 or Table 3/G.994.1 shall not be transmitted.

TABLE 4/G.994.1

Mandatory carrier sets

xDSL Recommendation(s)	Carrier set designation
Reserved for allocation by the ITU-T	A4

6.2 Modulation

All messages in G.994.1 are sent with one or more carrier sets. All carrier frequencies within a carrier set, and all carrier sets are simultaneously modulated with the same data bits using Differentially encoded binary Phase Shift Keying (DPSK). The transmit point is rotated 180 degrees from the previous point if the transmit bit is a 1, and the transmit point is rotated 0 degrees from the previous point if the transmit bit is a 0.

For each signal transmitted, the transmit signal shall have a rectangular pulse shaping, defined as:

$$s(t) = \left[\left(\sum_i \cos(2\pi f_i t + \phi_i) \right) \times \left(\sum_n A_n \times \text{rect}(t - nT) \right) \right] \otimes h_{tx}(t)$$

where:

- × means signal multiplication
- ⊗ means signal convolution

f_i are the G.994.1 carrier frequencies (defined in 6.1)

ϕ_i are the G.994.1 carrier phases (discretionary constants)

T is the symbol period

$T = (8/4312.5)$ seconds for the 4.3125 kHz signalling family and $(5/4000)$ seconds for the 4 kHz signalling family

$A_n = +1$ or -1 and is differentially encoded according to:

$A_n = A_{n-1}$ if $b_n = 0$;

$A_n = -A_{n-1}$ if $b_n = 1$.

b_n represents the bit transmitted in symbol n

$\text{rect}(t)$ is a rectangular pulse shape defined by

$\text{rect}(t) = 1$ if $|t| < T/2$;

$= 0$ otherwise.

h_{tx} represents the impulse response of the transmit filter.

For the 4.3125 kHz signalling family, the transmit filter shall have a bandwidth such that all of the -3 dB points of the filter shall have frequencies which differ at least 4.3125 kHz from any G.994.1 carrier frequency used.

The transmit filter for the 4 kHz signalling family is for further study.

7 Description of messages

7.1 CL - Capabilities List

This message may be sent by an HSTU-C in response to the reception of either a complete CLR message, or an intermediate frame of a segmented CLR message. It conveys a list of possible modes of operation of the xTU-C.

7.2 CLR - Capabilities List + Request

This message may be sent by an HSTU-R. It conveys a list of possible modes of operation of the xTU-R and requests the transmission of a CL message by the HSTU-C.

7.3 MR - Mode Request

This message may be sent by an HSTU-R. It requests the transmission of an MS message by the HSTU-C.

7.4 MS - Mode Select

This message may be sent by an HSTU-C or an HSTU-R. It requests the initiation of a particular mode of operation.

7.5 ACK(1) - Acknowledge, Type 1

This message either:

- acknowledges receipt of a complete CL message or an intermediate frame of a segmented CL message and ends a G.994.1 transaction; or
- acknowledges receipt of a complete MS message or an intermediate frame of a segmented MS message and initiates the G.994.1 session clear-down procedure specified in § 11.3.

7.6 ACK(2) - Acknowledge, Type 2

This message acknowledges receipt of an intermediate frame of a segmented CL, CLR or MS message and requests the transmission of the next frame of the message.

7.7 NAK-EF - Negative Acknowledge, Errored Frame

This message is sent in response to the reception of an errored frame. It aborts a G.994.1 session in accordance with the error recovery procedure specified in § 12.

7.8 NAK-NR - Negative Acknowledge, Not Ready

This message may be sent by an HSTU-C or an HSTU-R to acknowledge receipt of a complete MS message or an intermediate frame of a segmented MS message. It ends a G.994.1 transaction. It indicates that the receiving station is temporarily unable (i.e. Not Ready) to invoke the mode requested by the transmitting station but wishes to continue the G.994.1 session.

7.9 NAK-NS - Negative Acknowledge, Not Supported

This message may be sent by an HSTU-C or an HSTU-R to acknowledge receipt of a complete MS message or an intermediate frame of a segmented MS message. It ends a G.994.1 transaction. For a received message with the same or lower G.994.1 revision number, transmission of NAK-NS indicates that the receiving station either does not support or has disabled the mode requested by the transmitting station. For a received message with a higher G.994.1 revision number, transmission of NAK-NS indicates either reception of an unknown message type or reception of an unexpected message according to the transactions defined in this version of the Recommendation.

7.10 NAK-CD - Negative Acknowledge, Clear Down

This message may be sent in response to any frame of a message other than one of the NAK messages. It indicates that the received information was not understood. This may be due to an unknown message type (same or lower G.994.1 revision level), an unexpected message type according to the defined transactions (same or lower G.994.1 revision level), or a syntax error while parsing the message. Since a NAK-CD normally indicates a lack of compliance with Recommendation G.994.1, it initiates the G.994.1 session clear-down procedure specified in § 11.3.

7.11 REQ-MS - Request MS Message

This message may be sent by an HSTU-C in response to the reception of an MR message. It requests the transmission of an MS message by the HSTU-R. It indicates that the HSTU-C does not wish to select a mode and is deferring the mode selection to the HSTU-R.

7.12 REQ-MR - Request MR Message

This message may be sent by an HSTU-C in response to the reception of a complete MS message or an intermediate frame of a segmented MS message. It requests the transmission of an MR message by the HSTU-R. It indicates that the HSTU-C wishes to select the mode.

7.13 REQ-CLR - Request CLR Message

This message may be sent by an HSTU-C in response to the reception of either an MR message, a complete MS message, or an intermediate frame of a segmented MS message. It requests the transmission of a CLR message by the HSTU-R. It indicates that the HSTU-C wishes to perform a capabilities exchange.

8 Structure of messages

A message consists of one or more segments. Each segment is encapsulated in a frame.

8.1 Format convention

The basic format convention used for messages is illustrated in Figure 2/G.994.1. Bits are grouped into octets. The bits of each octet are shown horizontally and are numbered from 1 to 8. Octets are displayed vertically and are numbered from 1 to N.

The octets are transmitted in ascending numerical order. Within an octet, bit 1 is the first bit to be transmitted.

For fields that are contained within a single octet, the lowest numbered bit of the field represents the least significant bit (2^0). When a field spans multiple octets, the lowest numbered bit of the field in the highest numbered octet containing the field represents the least significant bit (2^0). The order of bit values within each octet increases as the bit number increases. The order of bit values from octet to octet increases as the octet number decreases. Figure 3/G.994.1 illustrates a field that spans two octets.

An exception to this convention is the Frame Check Sequence (FCS) field, which spans two octets. In this case, the order of bit values within the octets is reversed. Bit 1 of the first octet is the MSB and bit 8 of the second octet is the LSB (Figure 4/G.994.1).

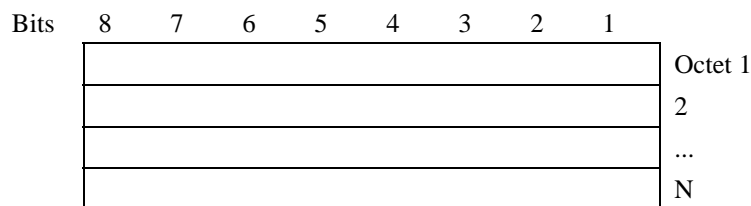

FIGURE 2/G.994.1

Format convention

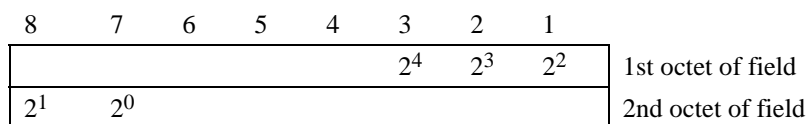

FIGURE 3/G.994.1

Field mapping convention

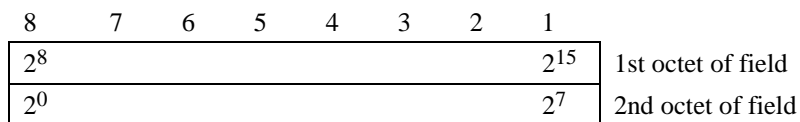

FIGURE 4/G.994.1

FCS mapping convention

8.2 Frame structure

The frame structure is shown in Figure 5/G.994.1. The contents of a frame shall consist of an integer number of octets.

Frames shall begin and end with standard HDLC flag octets (01111110) as defined in ISO/IEC 3309. At least three but not more than five flags shall be sent to begin a frame. At least two but not more than three flags shall follow the FCS of each frame.

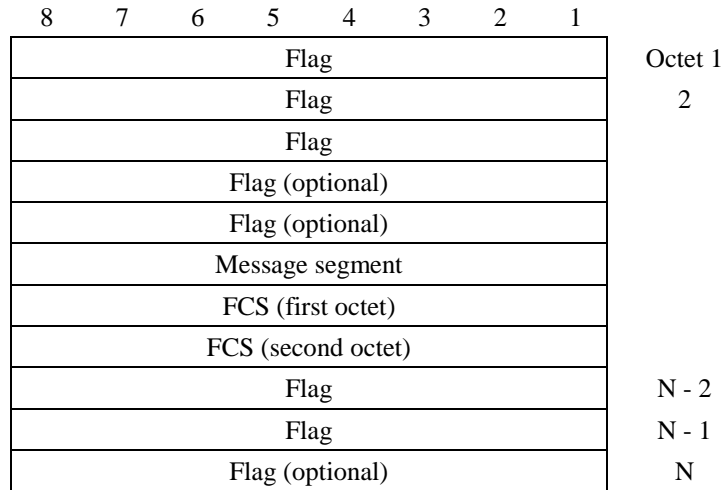

FIGURE 5/G.994.1
Frame structure

8.3 Frame check sequence field

The FCS field is 16 bits (2 octets) in length. As defined in ISO/IEC 3309, it shall be the one's complement of the sum (modulo 2) of:

- the remainder of $x^k (x^{15} + x^{14} + x^{13} + x^{12} + x^{11} + x^{10} + x^9 + x^8 + x^7 + x^6 + x^5 + x^4 + x^3 + x^2 + x + 1)$ divided (modulo 2) by the generator polynomial $x^{16} + x^{12} + x^5 + 1$, where k is the number of bits in the frame existing between, but not including, the last bit of the final opening flag and the first bit of the FCS, excluding octets inserted for transparency; and
- the remainder of the division (modulo 2) by the generator polynomial $x^{16} + x^{12} + x^5 + 1$, of the product of x^{16} by the content of the frame existing between, but not including, the last bit of the final opening flag and the first bit of the FCS, excluding octets inserted for transparency.

As a typical implementation at the transmitter, the initial content of the register of the device computing the remainder of the division is preset to all binary ONES and is then modified by division by the generator polynomial (as described above) on the information field. The one's complement of the resulting remainder is transmitted as the 16-bit FCS.

As a typical implementation at the receiver, the initial content of the register of the device computing the remainder of the division is preset to all binary ONES. The final remainder, after multiplication by x^{16} and then division (modulo 2) by the generator polynomial $x^{16} + x^{12} + x^5 + 1$

of the serial incoming protected bits and the FCS after removal of the transparency octets, will be 0001110100001111_2 (x^{15} through x^0 , respectively) in the absence of transmission errors.

8.4 Octet transparency

G.994.1 messages use the octet transparency method defined in ISO/IEC 3309. In this approach, any data that is equal to $7E_{16}$ (the Flag Sequence) or $7D_{16}$ (the Control Escape) are escaped as described below.

After Frame Check Sequence (FCS) computation, the transmitter examines the entire frame between the two Flag Sequences. Any data octets which are equal to the Flag Sequence or the Control Escape are replaced by a two octet sequence consisting of the Control Escape octet followed by the original octet Exclusive-OR'ed with hexadecimal 20_{16} . In summary, the following substitutions are made:

- a data octet of $7E_{16}$ is encoded as two octets: $7D_{16}, 5E_{16}$
- a data octet of $7D_{16}$ is encoded as two octets: $7D_{16}, 5D_{16}$

On reception, prior to FCS computation, each Control Escape octet ($7D_{16}$) is removed, and the following octet is exclusive-OR'ed with hexadecimal 20_{16} (unless the following octet is $7E_{16}$, which is the flag, and indicates the end of frame, and therefore an abort has occurred). In summary, the following substitutions are made:

- a sequence of $7D_{16}, 5E_{16}$ is replaced by the data octet $7E_{16}$
- a sequence of $7D_{16}, 5D_{16}$ is replaced by the data octet $7D_{16}$
- a sequence of $7D_{16}, 7E_{16}$ aborts the frame.

Since octet stuffing is used, the frame is guaranteed to have an integer number of octets.

8.5 Inter-frame time fill

In duplex mode, an integer number of flags shall be transmitted between frames. In half-duplex mode, silence shall be transmitted between frames.

9 Message coding format

9.1 General

The message information field consists of three components:

- a) an identification field (I), followed by;
- b) a standard information field (S); and
- c) an optional non-standard information field (NS).

This general structure is shown in Figure 6/G.994.1.

Identification (I) field	Standard information (S) field	Non-standard information (NS) field
-----------------------------	-----------------------------------	--

FIGURE 6/G.994.1

Information field structure

9.2 Coding format for parameters in the I and S fields

In both the I and S fields most of the information to be conveyed consists of parameters relating to particular modes, features or capabilities associated with the two stations.

In order to:

- a) encode these parameters in accordance with a consistent set of rules; and
- b) allow future extension to the parameter list in a way that permits present and future G.994.1 implementations to correctly parse the information field,

the parameters are linked together in a pre-defined tree structure. The order in which the parameters in the tree are transmitted and the use of delimiting bits that enable the tree to be reconstructed at the receiver are described in the rules set out below.

9.2.1 Parameter classification

Parameters (Pars) are classified as:

- NParS - Parameters which have no subparameters associated with them; and
- SPars - Parameters that have subparameters associated with them.

The general structure of this tree is as shown in Figure 7/G.994.1.

At level 1, the highest level of the tree, each SPars has associated with it a series of Pars (NParS and possibly SPars) at level 2 in the tree. At level 2 in the tree, each SPars has associated with it a series of NParS at level 3 in the tree. Level 3 is the lowest level in the tree. Therefore, there are no SPars at this level.

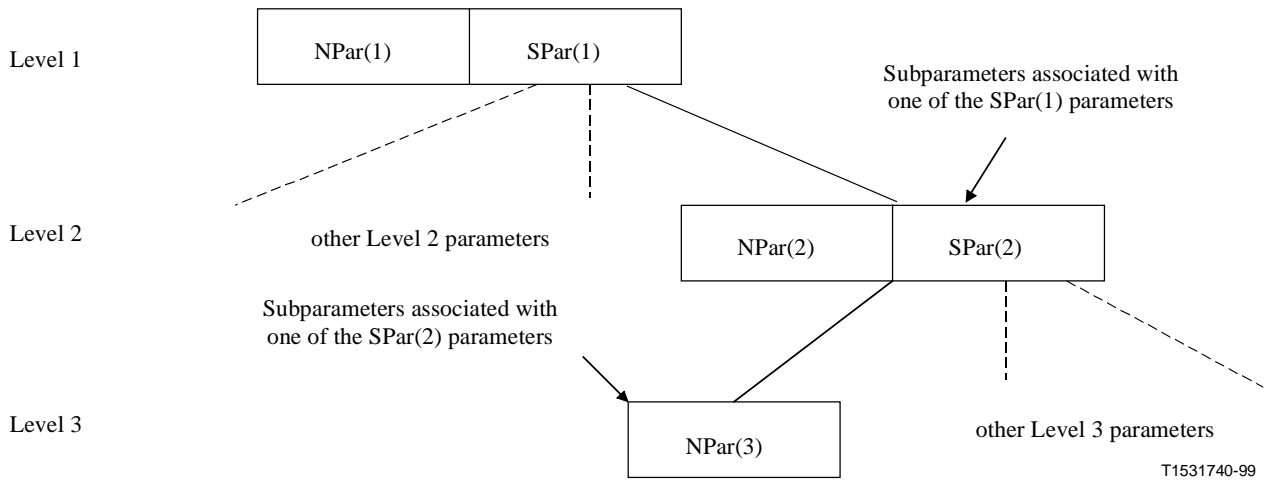

NPar(n) indicates a set of NPar parameters at level n in the tree.

FIGURE 7/G.994.1

Tree structure linking parameters in the I and S fields

9.2.2 Order of transmission of parameters

Parameters are binary encoded and transmitted serially. Parameters of the same type (i.e. level, classification and association) are transmitted sequentially as a parameter block consisting of an integral number of octets.

The order of transmission of NPar and SPar is specified in Figure 8/G.994.1.

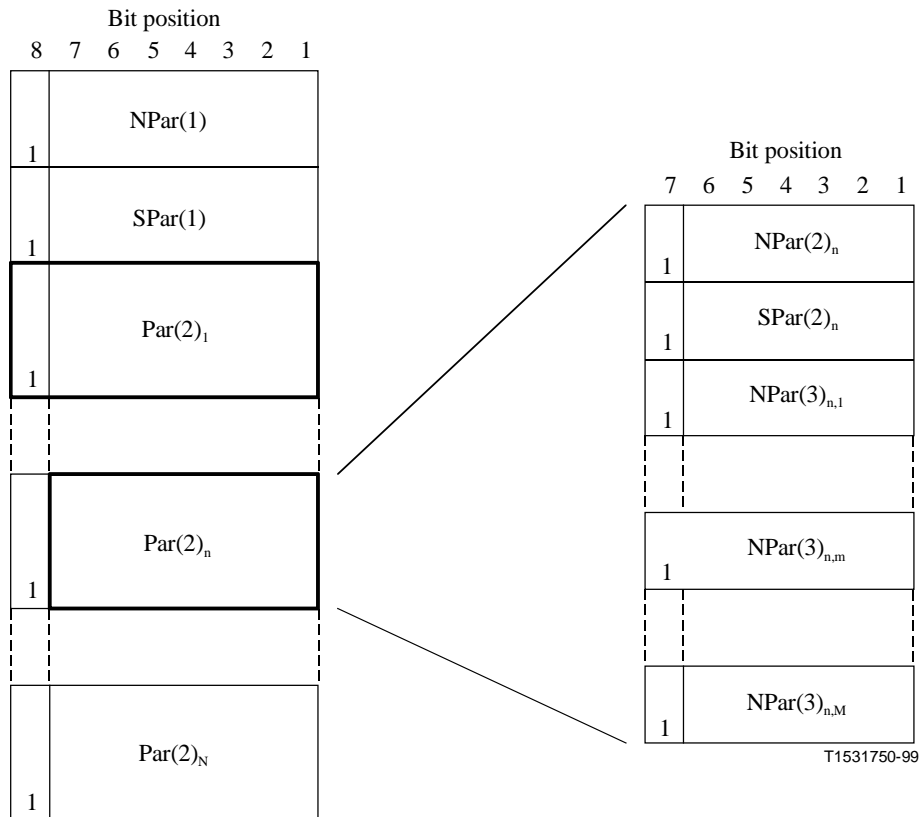

FIGURE 8/G.994.1

Order of transmission of NParams and SParams

$Par(2)_n$ indicates a set of level 2 parameters associated with the n th level 1 SPar, and consists of $NPar(2)_n$ parameters and possibly $SPar(2)_n$ parameters.

$NPar(3)_{n,m}$ indicates a set of level 3 NParams associated with the m th level 2 SPar which in turn is associated with the n th level 1 SPar.

Transmission of parameters begins with the first octet of $NPar(1)$ and ends with the last octet of $Par(2)_N$.

The order of transmission of the $Par(2)$ blocks is the same as the order of transmission of the corresponding $SPar(1)$ bits. Similarly, the order of transmission of the $NPar(3)_n$ blocks is the same as the order of transmission of the corresponding $SPar(2)_n$ bits.

9.2.3 Delimiting and parsing of parameter blocks

The use of delimiting bits is illustrated in Figure 8/G.994.1. Within each octet of a parameter block, at least one bit is defined as a delimiting bit. This is used to define the last octet in the block to be transmitted. A binary ZERO in this bit position indicates that there is at least one additional octet in the block to be transmitted. A binary ONE in this bit position indicates the last octet in the block to be transmitted.

Bit 8 is used to delimit the $NPar(1)$ block, the $SPar(1)$ block, and each of the $Par(2)$ blocks. There are N of these $Par(2)$ blocks, one for each of the capabilities in the $SPar(1)$ block that is enabled (set to binary ONE).

In order for this parsing rule to function correctly, both the identification field (I) and the standard information field (S) shall include at least one octet of NPar(1) and at least one octet of SPar(1).

Bit 7 is used to delimit each NPar(2) block, each SPar(2) block, and each of the associated NPar(3) blocks. Figure 8/G.994.1 indicates that there are M of these NPar(3) blocks, one for each of the capabilities in the SPar(2)_n block that is enabled (set to binary ONE). M may be different for each of the Par(2) blocks.

A Par(2) block may either contain both NPar(2) and SPar(2) octets, or NPar(2) octets alone. To indicate that a Par(2) block contains only NPar(2) octets, bits 7 and 8 are both set to binary ONE in the last NPar(2) octet to be transmitted.

Bits 1 through 7 at level 1 of the tree and bits 1 through 6 at levels 2 and 3 of the tree may be used to encode parameters.

Octets at the end of any Par block that would have contained all ZEROs except for delimiting bits may be omitted from transmission, provided that terminating bits are correctly set for the transmitted octets.

To allow for compatibility with future revisions of this Recommendation, receivers shall parse all parameter blocks and ignore information that is not understood. However, to be able to correctly parse the parameter blocks, it is necessary to pay attention to the number of SPar(1) and SPar(2) bits that are set, even if the meaning of one or more of these bits is not understood.

9.3 Identification field (I)

The identification field consists of four components:

- a) a one octet message type field; followed by
- b) a one octet revision number field;
- c) an 8 octet Vendor ID field; and
- d) a bit-encoded parameter field.

This general structure is shown in Figure 9/G.994.1.

Message type field	Revision number field	Vendor ID field	Bit-encoded parameter field
--------------------	-----------------------	-----------------	-----------------------------

FIGURE 9/G.994.1

Identification field structure

9.3.1 Message type

The purpose of the message type field is to identify the message type of the frame. The field is one octet in length and occupies the first octet in the identification field. The tree structure encoding rules specified in § 9.2 are not applicable to this field. The encoding shall be as shown in Table 5/G.994.1.

NOTE - Message types other than those specified in Table 5/G.994.1 are reserved for allocation by the ITU-T.

TABLE 5/G.994.1

Message type field format

Message type	Bit numbers							
	8	7	6	5	4	3	2	1
MS	0	0	0	0	0	0	0	0
MR	0	0	0	0	0	0	0	1
CL	0	0	0	0	0	0	1	0
CLR	0	0	0	0	0	0	1	1
ACK(1)	0	0	0	1	0	0	0	0
ACK(2)	0	0	0	1	0	0	0	1
NAK-EF	0	0	1	0	0	0	0	0
NAK-NR	0	0	1	0	0	0	0	1
NAK-NS	0	0	1	0	0	0	1	0
NAK-CD	0	0	1	0	0	0	1	1
REQ-MS	0	0	1	1	0	1	0	0
REQ-MR	0	0	1	1	0	1	0	1
REQ-CLR	0	0	1	1	0	1	1	1

9.3.2 Revision number

The purpose of the revision number field is to identify the revision number of G.994.1 to which the equipment conforms.

NOTE - The revision number of G.994.1 will not be updated with the addition of new codepoints. It will be updated when a structural change is made. Examples of structural changes are the addition of new message types and new transactions. To insure backward compatibility, future revisions will include, without change, all of the existing transactions, messages and information from previous revisions.

If the received message is an MS, it is the expected message according to the defined transactions, and it can be parsed correctly, it shall be ACKed if the features are supported, independent of the revision number of the message.

If the received message is of an unknown type or is not the expected message according to the defined transactions, and the revision number field indicates a higher revision, a NAK-NS shall be sent.

The field is one octet in length and occupies the second octet of the identification field. The tree structure encoding rules specified in § 9.2 are not applicable to this field. The encoding shall be in accordance with Table 6/G.994.1.

NOTE - Revision numbers other than those specified in Table 6/G.994.1 are reserved for allocation by the ITU-T.

TABLE 6/G.994.1

Revision number field format

Revision number	Bit numbers							
	8	7	6	5	4	3	2	1
Revision 1	0	0	0	0	0	0	0	1

9.3.3 Vendor ID field

Coding for the Vendor ID field is shown in Table 7/G.994.1. The tree structure rules specified in § 9.2 are not applicable to this field. For MR, MS, ACK, NAK and REQ messages, the vendor ID field is not used and is therefore of zero length.

TABLE 7/G.994.1

Vendor ID information block

T.35 country code (2 octets - see NOTE 1)
provider code (vendor identification) (4 octets - see NOTE 2)
vendor specific information (2 octets)
NOTE 1 - If the bits in the first octet are not all set to binary ONE, the bits in the second octet shall be set to binary ZERO by the transmitter and ignored by the receiver. NOTE 2 - Specification of the coding and order of transmission of this field is the responsibility of the regional standards body allocating the provider code. See Appendix 2 for provider code contact information.

9.3.4 Parameter field

This field contains parameters that are independent of the mode to be selected and are typically either service or application related.

The parameter field of CL, CLR and MS messages is encoded in accordance with the rules described in § 9.2. For MR, ACK, NAK and REQ messages, the parameter field is not used and is therefore of zero length.

The parameter field consists of a set of octets in which each parameter is assigned a unique bit position. A binary ONE in the assigned bit position indicates that the parameter is valid. The validity of multiple parameters may be conveyed by transmitting a binary ONE in each bit position corresponding to a valid parameter.

The level 1 and 2 NPars and SPars are listed in Table 8/G.994.1 through Table 9.6/G.994.1.

TABLE 8/G.994.1

Identification field - NPar(1) coding

NPar(1)s	8	7	6	5	4	3	2	1
Reserved for allocation by the ITU-T	x	x	x	x	x	x	x	1
Reserved for allocation by the ITU-T	x	x	x	x	x	x	1	x
Reserved for allocation by the ITU-T	x	x	x	x	x	1	x	x
Reserved for allocation by the ITU-T	x	x	x	x	1	x	x	x
Reserved for allocation by the ITU-T	x	x	x	1	x	x	x	x
Reserved for allocation by the ITU-T	x	x	1	x	x	x	x	x
Non-standard field	x	1	x	x	x	x	x	x
No parameters set in this octet	x	0	0	0	0	0	0	0

TABLE 9/G.994.1

Identification field - SPar(1) coding

SPar(1)s	8	7	6	5	4	3	2	1
Net data rate upstream (NOTE 1)	x	x	x	x	x	x	x	1
Net data rate downstream (NOTE 1)	x	x	x	x	x	x	1	x
Data flow characteristics upstream (NOTE 2)	x	x	x	x	x	1	x	x
Data flow characteristics downstream (NOTE 2)	x	x	x	x	1	x	x	x
xTU-R splitter information (NOTE 3)	x	x	x	1	x	x	x	x
xTU-C splitter information (NOTE 3)	x	x	1	x	x	x	x	x
Reserved for allocation by the ITU-T	x	1	x	x	x	x	x	x
No parameters set in this octet	x	0	0	0	0	0	0	0

NOTE 1 - In a CLR or CL message, the data rates indicated in G.994.1 are of informative nature and do not imply any requirements on the net data rate during data mode. The data rate values are set and used by layers higher than the xTU-x although an xTU-x may monitor the information. The data rate values are useful to help the higher layers to select between the various G.99x.x transceivers based upon information indicated by an application layer. In an MS message, if the xTU-x is capable of supporting the information, it shall respond with an ACK. If the xTU-x is either not capable of supporting the information or the negotiation of this information, it shall respond with a NAK-NS.

NOTE 2 - In a CLR or CL message, the latencies indicated in G.994.1 are of informative nature and do not imply any requirements on the latency during data mode. The latency values are set and used by layers higher than the xTU-x although a xTU-x may monitor the information. The latency values are useful to help the higher layers to select between the various G.99x.x transceivers and coding parameters based upon information indicated by an application layer. In an MS message, if the xTU-x is capable of supporting the information, it shall respond with an ACK. If the xTU-x is either not capable of supporting the information or the negotiation of this information, it shall respond with a NAK-NS.

NOTE 3 - Splitter information is only conveyed by an xTU-x if it has the capability of determining the local splitter information. Splitter information is only a capabilities indication, and shall not be included in an MS message.

TABLE 9.1/G.994.1

Identification field - Net data rate upstream NPar(2) coding - Octet 1

Net data rate upstream NPar(2)s	8	7	6	5	4	3	2	1
Unspecified by terminal	x	x	0	0	0	0	0	0
Maximum net data rate upstream (bits 5-1 x 64 kbit/s)	x	x	0	x	x	x	x	x
Maximum net data rate upstream (bits 5-1 x 2 Mbit/s)	x	x	1	x	x	x	x	x
Reserved for allocation by the ITU-T	x	x	1	1	1	1	1	1

TABLE 9.1.1/G.994.1

Identification field - Net data rate upstream NPar(2) coding - Octet 2

Net data rate upstream NPar(2)s	8	7	6	5	4	3	2	1
Unspecified by terminal	x	x	0	0	0	0	0	0
Minimum net data rate upstream (bits 5-1 x 64 kbit/s)	x	x	0	x	x	x	x	x
Minimum net data rate upstream (bits 5-1 x 2 Mbit/s)	x	x	1	x	x	x	x	x
Reserved for allocation by the ITU-T	x	x	1	1	1	1	1	1

TABLE 9.1.2/G.994.1

Identification field - Net data rate upstream NPar(2) coding - Octet 3

Net data rate upstream NPar(2)s	8	7	6	5	4	3	2	1
Unspecified by terminal	x	x	0	0	0	0	0	0
Average net data rate upstream (bits 5-1 x 64 kbit/s)	x	x	0	x	x	x	x	x
Average net data rate upstream (bits 5-1 x 2 Mbit/s)	x	x	1	x	x	x	x	x
Reserved for allocation by the ITU-T	x	x	1	1	1	1	1	1

TABLE 9.2/G.994.1

Identification field - Net data rate downstream NPar(2) coding - Octet 1

Net data rate downstream NPar(2)s	8	7	6	5	4	3	2	1
Unspecified by terminal	x	x	0	0	0	0	0	0
Maximum net data rate downstream (bits 5-1 x 64 kbit/s)	x	x	0	x	x	x	x	x
Maximum net data rate downstream (bits 5-1 x 2 Mbit/s)	x	x	1	x	x	x	x	x
Reserved for allocation by the ITU-T	x	x	1	1	1	1	1	1

TABLE 9.2.1/G.994.1

Identification field - Net data rate downstream NPar(2) coding - Octet 2

Net data rate downstream NPar(2)s	8	7	6	5	4	3	2	1
Unspecified by terminal	x	x	0	0	0	0	0	0
Minimum net data rate downstream (bits 5-1 x 64 kbit/s)	x	x	0	x	x	x	x	x
Minimum net data rate downstream (bits 5-1 x 2 Mbit/s)	x	x	1	x	x	x	x	x
Reserved for allocation by the ITU-T	x	x	1	1	1	1	1	1

TABLE 9.2.2/G.994.1

Identification field - Net data rate downstream NPar(2) coding - Octet 3

Net data rate downstream NPar(2)s	8	7	6	5	4	3	2	1
Unspecified by terminal	x	x	0	0	0	0	0	0
Average net data rate downstream (bits 5-1 x 64 kbit/s)	x	x	0	x	x	x	x	x
Average net data rate downstream (bits 5-1 x 2 Mbit/s)	x	x	1	x	x	x	x	x
Reserved for allocation by the ITU-T	x	x	1	1	1	1	1	1

TABLE 9.3/G.994.1

Identification field - Data flow characteristics upstream NPar(2) coding - Octet 1

Data flow characteristics upstream NPar(2)s	8	7	6	5	4	3	2	1
Unspecified by terminal	x	x	0	0	0	0	0	0
Maximum latency upstream (bits 5 to 1) x 1 ms	x	x	0	x	x	x	x	x
Maximum latency upstream (4 + bits 5 to 1) x 10 ms	x	x	1	x	x	x	x	x
Reserved for allocation by the ITU-T	x	x	1	1	1	1	1	1

TABLE 9.3.1/G.994.1

Identification field - Data flow characteristics upstream NPar(2) coding - Octet 2

Data flow characteristics upstream Npar(2)s	8	7	6	5	4	3	2	1
Unspecified by terminal	x	x	0	0	0	0	0	0
Average latency upstream (bits 5 to 1) x 1 ms	x	x	0	x	x	x	x	x
Average latency upstream (4 + bits 5 to 1) x 10 ms	x	x	1	x	x	x	x	x
Reserved for allocation by the ITU-T	x	x	1	1	1	1	1	1

TABLE 9.4/G.994.1

Identification field - Data flow characteristics downstream NPar(2) coding - Octet 1

Data flow characteristics downstream NPar(2)s	8	7	6	5	4	3	2	1
Unspecified by terminal	x	x	0	0	0	0	0	0
Maximum latency downstream (bits 5 to 1) x 1 ms	x	x	0	x	x	x	x	x
Maximum latency downstream (4 + bits 5 to 1) x 10 ms	x	x	1	x	x	x	x	x
Reserved for allocation by the ITU-T	x	x	1	1	1	1	1	1

TABLE 9.4.1/G.994.1

Identification field - Data flow characteristics downstream NPar(2) coding - Octet 2

Data flow characteristics downstream NPar(2)s	8	7	6	5	4	3	2	1
Unspecified by terminal	x	x	0	0	0	0	0	0
Average latency downstream (bits 5 to 1) x 1 ms	x	x	0	x	x	x	x	x
Average latency downstream (4 + bits 5 to 1) x 10 ms	x	x	1	x	x	x	x	x
Reserved for allocation by the ITU-T	x	x	1	1	1	1	1	1

TABLE 9.5/G.994.1

Identification field - xTU-R splitter information NPar(2) coding

xTU-R splitter information NPar(2)s	8	7	6	5	4	3	2	1
LPF is voice	x	x	x	x	x	x	x	1
LPF is USA ISDN	x	x	x	x	x	x	1	x
LPF is European ISDN	x	x	x	x	x	1	x	x
Reserved for allocation by the ITU-T	x	x	x	x	1	x	x	x
Reserved for allocation by the ITU-T	x	x	x	1	x	x	x	x
Non-standard LPF	x	x	1	x	x	x	x	x
No parameters in this octet	x	x	0	0	0	0	0	0

TABLE 9.6/G.994.1

Identification field - xTU-C splitter information NPar(2) coding

xTU-C splitter information NPar(2)s	8	7	6	5	4	3	2	1
HPF is 25 kHz (voice)	x	x	x	x	x	x	x	1
HPF is 90 kHz USA ISDN	x	x	x	x	x	x	1	x
HPF is 150 kHz (ADSL with European ISDN)	x	x	x	x	x	1	x	x
HPF is 300 kHz (VDSL)	x	x	x	x	1	x	x	x
Reserved for allocation by the ITU-T	x	x	x	1	x	x	x	x
Non-standard HPF	x	x	1	x	x	x	x	x
No parameters in this octet	x	x	0	0	0	0	0	0

9.4 Standard information field (S)

In the standard information field the parameters represent modes of working or capabilities relating to the xTU-R or xTU-C.

The standard information field of CL, CLR and MS messages is encoded in accordance with the rules described in § 9.2. For MR, ACK, NAK and REQ messages, the standard information field is not used and is therefore of zero length.

The standard information field consists of a set of octets in which each capability is assigned a unique bit position. A binary ONE in the assigned bit position indicates that the capability is valid.

For messages CL and CLR, the validity of multiple capabilities may be conveyed by transmitting a binary ONE in each bit position corresponding to a valid capability. For message MS, multiple capabilities may be selected only if they can all be supported simultaneously within the xTU concerned.

The level 1 Pars for MS, CL and CLR messages are listed in Table 10/G.994.1 and 11/G.994.1 and defined thereunder. Lower level Pars are listed in Table 11.1/G.994.1 through Table 11.10.2.3/G.994.1. The interpretation and use of these lower level Pars is defined in the respective xDSL Recommendations.

The spectrum information indicated in the NPar(3) fields associated with each of the xDSL Recommendations is of informative nature and does not imply any requirements on the transmit spectrum used during initialization and data mode. Regardless of the spectrum information, the transmit spectrum shall comply with their respective Recommendations. Spectrum information may only be included in a CLR or CL message, not in an MS message. The spectrum information associated with Recommendations G.992.1 and G.992.2 are coded in 8 bits (across 2 octets) as a binary representation of the tone index.

Maximums: up to and including the tone index

Minimums: above and including the tone index.

TABLE 10/G.994.1

Standard information field - NPar(1) coding

NPar(1)s	8	7	6	5	4	3	2	1
Voiceband: V.8 (NOTE 1)	x	x	x	x	x	x	x	1
Voiceband: V.8bis (NOTE 1)	x	x	x	x	x	x	1	x
Silent period (NOTE 2)	x	x	x	x	x	1	x	x
G.997.1 (NOTE 3)	x	x	x	x	1	x	x	x
Reserved for allocation by the ITU-T	x	x	x	1	x	x	x	x
Reserved for allocation by the ITU-T	x	x	1	x	x	x	x	x
Reserved for allocation by the ITU-T	x	1	x	x	x	x	x	x
No parameters in this octet	x	0	0	0	0	0	0	0

NOTE 1 - Setting this bit to binary ONE in an MS message initiates the G.994.1 session clear-down procedure specified in § 11.3, and requests a V.8 or V.8bis handshake in the voiceband, with the xTU-R taking on the roll of a calling station and the xTU-C taking on the roll of an answering station.

NOTE 2 - This bit shall be set to binary ONE in a CLR or CL message. Setting this bit to binary ONE in an MS message initiates the G.994.1 session clear-down procedure specified in § 11.3, and requests a silence period at the other transmitter of approximately 1 minute. The station that invoked the silent period by transmitting MS may terminate the silent period prior to the 1 minute by restarting a G.994.1 session.

NOTE 3 - The use of this bit is for further study and shall be set to binary ZERO in CLR, CL and MS.

TABLE 11/G.994.1

Standard information field - SPar(1) coding

SPar(1)s	8	7	6	5	4	3	2	1
G.992.1 - Annex A	x	x	x	x	x	x	x	1
G.992.1 - Annex B	x	x	x	x	x	x	1	x
G.992.1 - Annex C	x	x	x	x	x	1	x	x
G.992.2 - Annex A/B	x	x	x	x	1	x	x	x
G.992.2 - Annex C	x	x	x	1	x	x	x	x
Reserved for allocation by the ITU-T	x	x	1	x	x	x	x	x
Reserved for allocation by the ITU-T	x	1	x	x	x	x	x	x
No parameters in this octet	x	0	0	0	0	0	0	0

TABLE 11.1/G.994.1

Standard information field - G.992.1 Annex A NPar(2) coding

G.992.1 Annex A NPar(2)s	8	7	6	5	4	3	2	1
R-ACK1	x	x	x	x	x	x	x	1
R-ACK2	x	x	x	x	x	x	1	x
Reserved for allocation by the ITU-T	x	x	x	x	x	1	x	x
STM	x	x	x	x	1	x	x	x
ATM	x	x	x	1	x	x	x	x
G.997.1 - Clear EOC OAM	x	x	1	x	x	x	x	x
No parameters in this octet	x	x	0	0	0	0	0	0

TABLE 11.2/G.994.1

Standard information field - G.992.1 Annex A SPar(2) coding

G.992.1 Annex A SPar(2)s	8	7	6	5	4	3	2	1
Sub-channel information	x	x	x	x	x	x	x	1
Spectrum frequency upstream	x	x	x	x	x	x	1	x
Spectrum frequency downstream	x	x	x	x	x	1	x	x
Reserved for allocation by the ITU-T	x	x	x	x	1	x	x	x
Reserved for allocation by the ITU-T	x	x	x	1	x	x	x	x
Reserved for allocation by the ITU-T	x	x	1	x	x	x	x	x
No parameters in this octet	x	x	0	0	0	0	0	0

TABLE 11.2.1/G.994.1

**Standard information field - G.992.1 Annex A Sub-channel information
NPar(3) coding - Octet 1**

G.992.1 Annex A Sub-channel information NPar(3)s - Octet 1	8	7	6	5	4	3	2	1
AS0 downstream	x	x	x	x	x	x	x	1
AS1 downstream	x	x	x	x	x	x	1	x
AS2 downstream	x	x	x	x	x	1	x	x
AS3 downstream	x	x	x	x	1	x	x	x
LS0 downstream	x	x	x	1	x	x	x	x
Reserved for allocation by the ITU-T	x	x	1	x	x	x	x	x
No parameters in this octet	x	x	0	0	0	0	0	0

TABLE 11.2.1.1/G.994.1

**Standard information field - G.992.1 Annex A Sub-channel information
NPar(3) coding - Octet 2**

G.992.1 Annex A Sub-channel information NPar(3)s - Octet 2	8	7	6	5	4	3	2	1
LS1 downstream	x	x	x	x	x	x	x	1
LS2 downstream	x	x	x	x	x	x	1	x
LS0 upstream	x	x	x	x	x	1	x	x
LS1 upstream	x	x	x	x	1	x	x	x
LS2 upstream	x	x	x	1	x	x	x	x
Reserved for allocation by the ITU-T	x	x	1	x	x	x	x	x
No parameters in this octet	x	x	0	0	0	0	0	0

TABLE 11.2.2/G.994.1

**Standard information field - G.992.1 Annex A Spectrum frequency upstream
NPar(3) coding - Octet 1**

G.992.1 Annex A Spectrum frequency upstream NPar(3)s - Octet 1	8	7	6	5	4	3	2	1
spectrum minimum frequency upstream (bits 7 and 8)	x	x	0	0	0	0	x	x

TABLE 11.2.2.1/G.994.1

**Standard information field - G.992.1 Annex A Spectrum frequency upstream
NPar(3) coding - Octet 2**

G.992.1 Annex A Spectrum frequency upstream NPar(3)s - Octet 2	8	7	6	5	4	3	2	1
spectrum minimum frequency upstream (bits 1 to 6)	x	x	x	x	x	x	x	x

TABLE 11.2.2.2/G.994.1

**Standard information field - G.992.1 Annex A Spectrum frequency upstream
NPar(3) coding - Octet 3**

G.992.1 Annex A Spectrum frequency upstream NPar(3)s - Octet 3	8	7	6	5	4	3	2	1
spectrum maximum frequency upstream (bits 7 and 8)	x	x	0	0	0	0	x	x

TABLE 11.3/G.994.1

Standard information field - G.992.1 Annex B NPar(2) coding

G.992.1 Annex B NPar(2)s	8	7	6	5	4	3	2	1
R-ACK1	x	x	x	x	x	x	x	1
R-ACK2	x	x	x	x	x	x	1	x
Upstream tones 1 to 32	x	x	x	x	x	1	x	x
STM	x	x	x	x	1	x	x	x
ATM	x	x	x	1	x	x	x	x
G.997.1 - Clear EOC OAM	x	x	1	x	x	x	x	x
No parameters in this octet	x	x	0	0	0	0	0	0

TABLE 11.4/G.994.1

Standard information field - G.992.1 Annex B SPar(2) coding

G.992.1 Annex B SPar(2)s	8	7	6	5	4	3	2	1
Sub-channel information	x	x	x	x	x	x	x	1
Spectrum frequency upstream	x	x	x	x	x	x	1	x
Spectrum frequency downstream	x	x	x	x	x	1	x	x
Reserved for allocation by the ITU-T	x	x	x	x	1	x	x	x
Reserved for allocation by the ITU-T	x	x	x	1	x	x	x	x
Reserved for allocation by the ITU-T	x	x	1	x	x	x	x	x
No parameters in this octet	x	x	0	0	0	0	0	0

TABLE 11.4.1/G.994.1

**Standard information field - G.992.1 Annex B Sub-channel information
NPar(3) coding - Octet 1**

G.992.1 Annex B Sub-channel information NPar(3)s - Octet 1	8	7	6	5	4	3	2	1
AS0 downstream	x	x	x	x	x	x	x	1
AS1 downstream	x	x	x	x	x	x	1	x
AS2 downstream	x	x	x	x	x	1	x	x
AS3 downstream	x	x	x	x	1	x	x	x
LS0 downstream	x	x	x	1	x	x	x	x
Reserved for allocation by the ITU-T	x	x	1	x	x	x	x	x
No parameters in this octet	x	x	0	0	0	0	0	0

TABLE 11.4.1.1/G.994.1

**Standard information field - G.992.1 Annex B Sub-channel information
NPar(3) coding - Octet 2**

G.992.1 Annex B Sub-channel information NPar(3)s - Octet 2	8	7	6	5	4	3	2	1
LS1 downstream	x	x	x	x	x	x	x	1
LS2 downstream	x	x	x	x	x	x	1	x
LS0 upstream	x	x	x	x	x	1	x	x
LS1 upstream	x	x	x	x	1	x	x	x
LS2 upstream	x	x	x	1	x	x	x	x
Reserved for allocation by the ITU-T	x	x	1	x	x	x	x	x
No parameters in this octet	x	x	0	0	0	0	0	0

TABLE 11.4.2/G.994.1

**Standard information field - G.992.1 Annex B Spectrum frequency upstream
NPar(3) coding - Octet 1**

G.992.1 Annex B Spectrum frequency upstream NPar(3)s - Octet 1	8	7	6	5	4	3	2	1
spectrum minimum frequency upstream (bits 7 and 8)	x	x	0	0	0	0	x	x

TABLE 11.4.2.1/G.994.1

**Standard information field - G.992.1 Annex B Spectrum frequency upstream
NPar(3) coding - Octet 2**

G.992.1 Annex B Spectrum frequency upstream NPar(3)s - Octet 2	8	7	6	5	4	3	2	1
spectrum minimum frequency upstream (bits 1 to 6)	x	x	x	x	x	x	x	x

TABLE 11.4.2.2/G.994.1

**Standard information field - G.992.1 Annex B Spectrum frequency upstream
NPar(3) coding - Octet 3**

G.992.1 Annex B Spectrum frequency upstream NPar(3)s - Octet 3	8	7	6	5	4	3	2	1
spectrum maximum frequency upstream (bits 7 and 8)	x	x	0	0	0	0	x	x

TABLE 11.4.2.3/G.994.1

**Standard information field - G.992.1 Annex B Spectrum frequency upstream
NPar(3) coding - Octet 4**

G.992.1 Annex B Spectrum frequency upstream NPar(3)s - Octet 4	8	7	6	5	4	3	2	1
spectrum maximum frequency upstream (bits 1 to 6)	x	x	x	x	x	x	x	x

TABLE 11.4.3/G.994.1

**Standard information field - G.992.1 Annex B Spectrum frequency downstream
NPar(3) coding - Octet 1**

G.992.1 Annex B Spectrum frequency downstream NPar(3)s - Octet 1	8	7	6	5	4	3	2	1
spectrum minimum frequency downstream (bits 7 and 8)	x	x	0	0	0	0	x	x

TABLE 11.4.3.1/G.994.1

**Standard information field - G.992.1 Annex B Spectrum frequency downstream
NPar(3) coding - Octet 2**

G.992.1 Annex B Spectrum frequency downstream NPar(3)s - Octet 2	8	7	6	5	4	3	2	1
spectrum minimum frequency downstream (bits 1 to 6)	x	x	x	x	x	x	x	x

TABLE 11.4.3.2/G.994.1

**Standard information field - G.992.1 Annex B Spectrum frequency downstream
NPar(3) coding - Octet 3**

G.992.1 Annex B Spectrum frequency downstream NPar(3)s - Octet 3	8	7	6	5	4	3	2	1
spectrum maximum frequency downstream (bits 7 and 8)	x	x	0	0	0	0	x	x

TABLE 11.4.3.3/G.994.1

**Standard information field - G.992.1 Annex B Spectrum frequency downstream
NPar(3) coding - Octet 4**

G.992.1 Annex B Spectrum frequency downstream NPar(3)s - Octet 4	8	7	6	5	4	3	2	1
spectrum maximum frequency downstream (bits 1 to 6)	x	x	x	x	x	x	x	x

TABLE 11.5/G.994.1

Standard information field - G.992.1 Annex C NPar(2) coding

G.992.1 Annex C NPar(2)s	8	7	6	5	4	3	2	1
R-ACK1	x	x	x	x	x	x	x	1
R-ACK2	x	x	x	x	x	x	1	x
DBM	x	x	x	x	x	1	x	x
STM	x	x	x	x	1	x	x	x
ATM	x	x	x	1	x	x	x	x
G.997.1 - Clear EOC OAM	x	x	1	x	x	x	x	x
No parameters in this octet	x	x	0	0	0	0	0	0

TABLE 11.6/G.994.1

Standard information field - G.992.1 Annex C SPar(2) coding

G.992.1 Annex C SPar(2)s	8	7	6	5	4	3	2	1
Sub-channel information	x	x	x	x	x	x	x	1
Spectrum frequency upstream	x	x	x	x	x	x	1	x
Spectrum frequency downstream	x	x	x	x	x	1	x	x
Reserved for allocation by the ITU-T	x	x	x	x	1	x	x	x
Reserved for allocation by the ITU-T	x	x	x	1	x	x	x	x
Reserved for allocation by the ITU-T	x	x	1	x	x	x	x	x
No parameters in this octet	x	x	0	0	0	0	0	0

TABLE 11.6.1/G.994.1

**Standard information field - G.992.1 Annex C Sub-channel information
NPar(3) coding - Octet 1**

G.992.1 Annex C Sub-channel information NPar(3)s - Octet 1	8	7	6	5	4	3	2	1
AS0 downstream	x	x	x	x	x	x	x	1
AS1 downstream	x	x	x	x	x	x	1	x
AS2 downstream	x	x	x	x	x	1	x	x
AS3 downstream	x	x	x	x	1	x	x	x
LS0 downstream	x	x	x	1	x	x	x	x
Reserved for allocation by the ITU-T	x	x	1	x	x	x	x	x
No parameters in this octet	x	x	0	0	0	0	0	0

TABLE 11.6.1.1/G.994.1

**Standard information field - G.992.1 Annex C Sub-channel information
NPar(3) coding - Octet 2**

G.992.1 Annex C Sub-channel information NPar(3)s - Octet 2	8	7	6	5	4	3	2	1
LS1 downstream	x	x	x	x	x	x	x	1
LS2 downstream	x	x	x	x	x	x	1	x
LS0 upstream	x	x	x	x	x	1	x	x
LS1 upstream	x	x	x	x	1	x	x	x
LS2 upstream	x	x	x	1	x	x	x	x
Reserved for allocation by the ITU-T	x	x	1	x	x	x	x	x
No parameters in this octet	x	x	0	0	0	0	0	0

TABLE 11.6.2/G.994.1

**Standard information field - G.992.1 Annex C Spectrum frequency upstream
NPar(3) coding - Octet 1**

G.992.1 Annex C Spectrum frequency upstream NPar(3)s - Octet 1	8	7	6	5	4	3	2	1
spectrum minimum frequency upstream (bits 7 and 8)	x	x	0	0	0	0	x	x

TABLE 11.6.2.1/G.994.1

**Standard information field - G.992.1 Annex C Spectrum frequency upstream
NPar(3) coding - Octet 2**

G.992.1 Annex C Spectrum frequency upstream NPar(3)s - Octet 2	8	7	6	5	4	3	2	1
spectrum minimum frequency upstream (bits 1 to 6)	x	x	x	x	x	x	x	x

TABLE 11.6.2.2/G.994.1

**Standard information field - G.992.1 Annex C Spectrum frequency upstream
NPar(3) coding - Octet 3**

G.992.1 Annex C Spectrum frequency upstream NPar(3)s - Octet 3	8	7	6	5	4	3	2	1
spectrum maximum frequency upstream (bits 7 and 8)	x	x	0	0	0	0	x	x

TABLE 11.6.2.3/G.994.1

**Standard information field - G.992.1 Annex C Spectrum frequency upstream
NPar(3) coding - Octet 4**

G.992.1 Annex C Spectrum frequency upstream NPar(3)s - Octet 4	8	7	6	5	4	3	2	1
spectrum maximum frequency upstream (bits 1 to 6)	x	x	x	x	x	x	x	x

TABLE 11.6.3/G.994.1

**Standard information field - G.992.1 Annex C Spectrum frequency downstream
NPar(3) coding - Octet 1**

G.992.1 Annex C Spectrum frequency downstream NPar(3)s - Octet 1	8	7	6	5	4	3	2	1
spectrum minimum frequency downstream (bits 7 and 8)	x	x	0	0	0	0	x	x

TABLE 11.6.3.1/G.994.1

**Standard information field - G.992.1 Annex C Spectrum frequency downstream
NPar(3) coding - Octet 2**

G.992.1 Annex C Spectrum frequency downstream NPar(3)s - Octet 2	8	7	6	5	4	3	2	1
spectrum minimum frequency downstream (bits 1 to 6)	x	x	x	x	x	x	x	x

TABLE 11.6.3.2/G.994.1

**Standard information field - G.992.1 Annex C Spectrum frequency downstream
NPar(3) coding - Octet 3**

G.992.1 Annex C Spectrum frequency downstream NPar(3)s - Octet 3	8	7	6	5	4	3	2	1
spectrum maximum frequency downstream (bits 7 and 8)	x	x	0	0	0	0	x	x

TABLE 11.6.3.3/G.994.1

**Standard information field - G.992.1 Annex C Spectrum frequency downstream
NPar(3) coding - Octet 4**

G.992.1 Annex C Spectrum frequency downstream NPar(3)s - Octet 4	8	7	6	5	4	3	2	1
spectrum maximum frequency downstream (bits 1 to 6)	x	x	x	x	x	x	x	x

TABLE 11.8.1.2/G.994.1

**Standard information field - G.992.2 Annex A/B Spectrum frequency upstream
NPar(3) coding - Octet 3**

G.992.2 Annex A/B Spectrum frequency upstream NPar(3)s - Octet 3	8	7	6	5	4	3	2	1
spectrum maximum frequency upstream (bits 7 and 8)	x	x	0	0	0	0	x	x

TABLE 11.8.1.3/G.994.1

**Standard information field - G.992.2 Annex A/B Spectrum frequency upstream
NPar(3) coding - Octet 4**

G.992.2 Annex A/B Spectrum frequency upstream NPar(3)s - Octet 4	8	7	6	5	4	3	2	1
spectrum maximum frequency upstream (bits 1 to 6)	x	x	x	x	x	x	x	x

TABLE 11.8.2/G.994.1

**Standard information field - G.992.2 Annex A/B Spectrum frequency downstream
NPar(3) coding - Octet 1**

G.992.2 Annex A/B Spectrum frequency downstream NPar(3)s - Octet 1	8	7	6	5	4	3	2	1
spectrum minimum frequency downstream (bits 7 and 8)	x	x	0	0	0	0	x	x

TABLE 11.8.2.1/G.994.1

**Standard information field - G.992.2 Annex A/B Spectrum frequency downstream
NPar(3) coding - Octet 2**

G.992.2 Annex A/B Spectrum frequency downstream NPar(3)s - Octet 2	8	7	6	5	4	3	2	1
spectrum minimum frequency downstream (bits 1 to 6)	x	x	x	x	x	x	x	x

TABLE 11.8.2.2/G.994.1

**Standard information field - G.992.2 Annex A/B Spectrum frequency downstream
NPar(3) coding - Octet 3**

G.992.2 Annex A/B Spectrum frequency downstream NPar(3)s - Octet 3	8	7	6	5	4	3	2	1
spectrum maximum frequency downstream (bits 7 and 8)	x	x	0	0	0	0	x	x

TABLE 11.8.2.3/G.994.1

**Standard information field - G.992.2 Annex A/B Spectrum frequency downstream
NPar(3) coding - Octet 4**

G.992.2 Annex A/B Spectrum frequency downstream NPar(3)s - Octet 4	8	7	6	5	4	3	2	1
spectrum maximum frequency downstream (bits 1 to 6)	x	x	x	x	x	x	x	x

TABLE 11.9/G.994.1

Standard information field - G.992.2 Annex C NPar(2) coding

G.992.2 Annex C NPar(2)s	8	7	6	5	4	3	2	1
R-ACK1	x	x	x	x	x	x	x	1
R-ACK2	x	x	x	x	x	x	1	x
DBM	x	x	x	x	x	1	x	x
Fast retrain	x	x	x	x	1	x	x	x
RS16	x	x	x	1	x	x	x	x
G.997.1 - Clear EOC OAM	x	x	1	x	x	x	x	x
No parameters in this octet	x	x	0	0	0	0	0	0

TABLE 11.10/G.994.1

Standard information field - G.992.2 Annex C SPar(2) coding

G.992.2 Annex C SPar(2)s	8	7	6	5	4	3	2	1
Reserved for allocation by the ITU-T	x	x	x	x	x	x	x	1
Spectrum frequency upstream	x	x	x	x	x	x	1	x
Spectrum frequency downstream	x	x	x	x	x	1	x	x
Reserved for allocation by the ITU-T	x	x	x	x	1	x	x	x
Reserved for allocation by the ITU-T	x	x	x	1	x	x	x	x
Reserved for allocation by the ITU-T	x	x	1	x	x	x	x	x
No parameters in this octet	x	x	0	0	0	0	0	0

TABLE 11.10.1/G.994.1

**Standard information field - G.992.2 Annex C Spectrum frequency upstream
NPar(3) coding - Octet 1**

G.992.2 Annex C Spectrum frequency upstream NPar(3)s - Octet 1	8	7	6	5	4	3	2	1
spectrum minimum frequency upstream (bits 7 and 8)	x	x	0	0	0	0	x	x

TABLE 11.10.1.1/G.994.1

**Standard information field - G.992.2 Annex C Spectrum frequency upstream
NPar(3) coding - Octet 2**

G.992.2 Annex C Spectrum frequency upstream NPar(3)s - Octet 2	8	7	6	5	4	3	2	1
spectrum minimum frequency upstream (bits 1 to 6)	x	x	x	x	x	x	x	x

TABLE 11.10.1.2/G.994.1

**Standard information field - G.992.2 Annex C Spectrum frequency upstream
NPar(3) coding - Octet 3**

G.992.2 Annex C Spectrum frequency upstream NPar(3)s - Octet 3	8	7	6	5	4	3	2	1
spectrum maximum frequency upstream (bits 7 and 8)	x	x	0	0	0	0	x	x

TABLE 11.10.1.3/G.994.1

**Standard information field - G.992.2 Annex C Spectrum frequency upstream
NPar(3) coding - Octet 4**

G.992.2 Annex C Spectrum frequency upstream NPar(3)s - Octet 4	8	7	6	5	4	3	2	1
spectrum maximum frequency upstream (bits 1 to 6)	x	x	x	x	x	x	x	x

TABLE 11.10.2/G.994.1

**Standard information field - G.992.2 Annex C Spectrum frequency downstream
NPar(3) coding - Octet 1**

G.992.2 Annex C Spectrum frequency downstream NPar(3)s - Octet 1	8	7	6	5	4	3	2	1
spectrum minimum frequency downstream (bits 7 and 8)	x	x	0	0	0	0	x	x

TABLE 11.10.2.1/G.994.1

**Standard information field - G.992.2 Annex C Spectrum frequency downstream
NPar(3) coding - Octet 2**

G.992.2 Annex C Spectrum frequency downstream NPar(3)s - Octet 2	8	7	6	5	4	3	2	1
spectrum minimum frequency downstream (bits 1 to 6)	x	x	x	x	x	x	x	x

TABLE 11.10.2.2/G.994.1

**Standard information field - G.992.2 Annex C Spectrum frequency downstream
NPar(3) coding - Octet 3**

G.992.2 Annex C Spectrum frequency downstream NPar(3)s - Octet 3	8	7	6	5	4	3	2	1
spectrum maximum frequency downstream (bits 7 and 8)	x	x	0	0	0	0	x	x

TABLE 11.10.2.3/G.994.1

**Standard information field - G.992.2 Annex C Spectrum frequency downstream
NPar(3) coding - Octet 4**

G.992.2 Annex C Spectrum frequency downstream NPar(3)s - Octet 4	8	7	6	5	4	3	2	1
spectrum maximum frequency downstream (bits 1 to 6)	x	x	x	x	x	x	x	x

9.5 Non-standard information field (NS)

MS, CL, and CLR messages may optionally contain a non-standard information field to convey information beyond that defined in this Recommendation. For MR, ACK, NAK and REQ messages, the non-standard information field is not used and is therefore of zero length.

When non-standard information is to be sent, the "Non-standard field" parameter shall be set to binary ONE in the identification field of the transmitted message (see Table 8/G.994.1).

The non-standard information field may be composed of one or more non-standard information blocks. The format of the non-standard information field is shown in Figure 10/G.994.1. The first octet of the non-standard information field shall indicate the number of non-standard information blocks to follow.

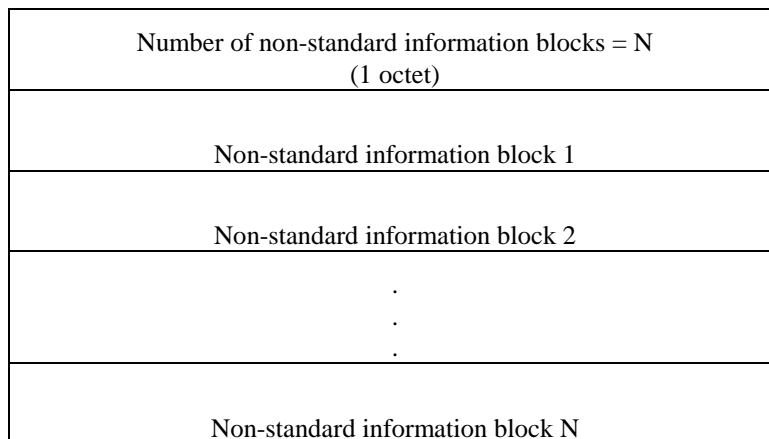
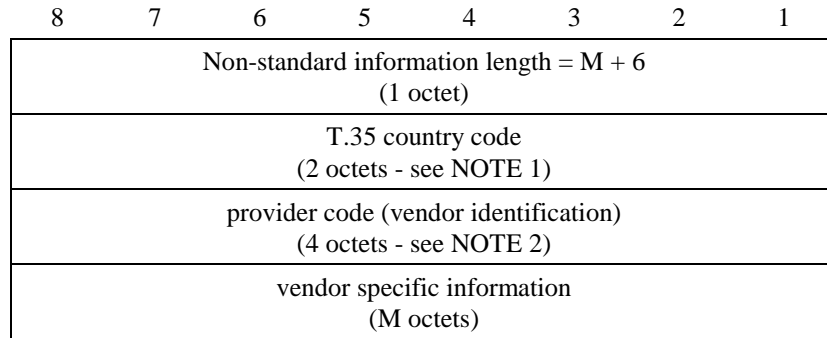

FIGURE 10/G.994.1

Non-standard information field (NS) format

Each non-standard information block (see Figure 11/G.994.1) is composed of:

- a length indicator (one octet) specifying the length of the remainder of the block;
- a country code (2 octets), as defined in Recommendation T.35;
- a 4 octet provider code as specified by the country identified in Recommendation T.35;
and
- non-standard information (M octets).



NOTE 1 - If the bits in the first octet are not all set to binary ONE, the bits in the second octet shall be set to binary ZERO by the transmitter and ignored by the receiver.

NOTE 2 - Specification of the coding and order of transmission of this field is the responsibility of the regional standards body allocating the provider code. See Appendix 2 for provider code contact information.

FIGURE 11/G.994.1

Non-standard information block format

9.6 Overall message composition

Table 12/G.994.1 shows which fields are permitted in each message type. An "X" indicates that the field shall be included whilst a "-" indicates that the field shall not be included.

Once a Transaction C (See §10.1) has been completed, any subsequent MS message within the same G.994.1 session shall only contain those octets of the identification (I) and standard information (S) fields, and those blocks of non-standard information (NS) that were contained in both the CLR and CL messages of the previous Transaction C.

TABLE 12/G.994.1

Overall message composition

Messages	IDENTIFICATION			STANDARD INFORMATION	NON-STANDARD INFORMATION
	Message type and revision (2 octets)	Vendor ID (8 octets)	Service and channel parameters (NOTE 1)	Modulations and Protocols available (NOTE 2)	(NOTE 3) $(1 + \sum_{i=1}^N (7 + M_i))$ octets
MR	X	-	-	-	-
CLR	X	X	X	X	as necessary
CL	X	X	X	X	as necessary
MS	X	-	X	X	as necessary
ACK	X	-	-	-	-
NAK	X	-	-	-	-
REQ	X	-	-	-	-

NOTE 1 - As defined in Table 8/G.994.1 through Table 9.6/G.994.1.
NOTE 2 - As defined in Table 10/G.994.1 through Table 11.10.2.3/G.994.1.
NOTE 3 - As defined in Figure 10/G.994.1 and Figure 11/G.994.1.

10 G.994.1 transactions

All permitted G.994.1 transactions are described in this clause.

An overview of the set of basic transactions specified in G.994.1, and the use of ACK(1) is given in § 10.1. The use of REQ-MS, REQ-MR and REQ-CLR to create extended transactions is described in § 10.2. Message segmentation and the use of ACK(2) is discussed in § 10.3. The complete specification of all state transitions permitted during a G.994.1 session is contained in § 10.4.

Error recovery procedures and the use of NAK-EF are discussed in § 12.

10.1 Basic transactions

Basic transactions may be classified as one of two types:

- those that exchange and negotiate capabilities between the HSTU-C and HSTU-R; and
- those that select a mode of operation.

Table 13/G.994.1 shows the set of basic transactions specified in G.994.1. Each transaction is initiated by the HSTU-R, and ends with an ACK(1). With basic transactions, the HSTU-R controls the negotiation procedure. At the end of a basic G.994.1 transaction, the stations shall either terminate the G.994.1 session (applies to transactions A, B and C) as specified in § 11.3, or shall go to the Initial HSTU-x Transaction state (applies to transaction C only) as shown in Figure 12/G.994.1 or Figure 13/G.994.1.

NOTE - The continuation of G.994.1 modulation after the conclusion of the G.994.1 session, for the purpose of implementing other protocols (for example G.997.1 - see Table 10/G.994.1), is for further study.

TABLE 13/G.994.1

Basic G.994.1 transactions

Transaction identifier	HSTU-R	HSTU-C	HSTU-R
A	MS →	ACK(1)	
B	MR →	MS →	ACK(1)
C	CLR →	CL →	ACK(1)

10.1.1 Transaction A

In Transaction A, the HSTU-R selects a mode of operation and requests that the HSTU-C transition to the selected mode. When the HSTU-C responds with an ACK(1) message, both stations shall transition to the selected mode.

If the HSTU-R cannot determine a common mode of operation (either standard or non-standard) from previous capabilities exchanges, or is not prepared to select a mode at this time, it shall send an MS message with the Non-standard field bit in Table 8/G.994.1 and all coding points in Table 10/G.994.1 and Table 11/G.994.1 set to binary ZERO. When the HSTU-C receives this message, it shall respond with an ACK(1) message. The HSTU-R shall then initiate the clear-down procedure specified in § 11.3.

10.1.2 Transaction B

In Transaction B, the HSTU-R requests that the HSTU-C select the mode of operation. The HSTU-C selects the mode by transmitting an MS message. When the HSTU-R responds with an ACK(1) message, both stations shall transition to the selected mode.

If the HSTU-C cannot determine a common mode of operation (either standard or non-standard) from previous capabilities exchanges, or is not prepared to select a mode at this time, it shall send an MS message with the Non-standard field bit in Table 8/G.994.1 and all coding points in Table 10/G.994.1 and Table 11/G.994.1 set to binary ZERO. When the HSTU-R receives this message, it shall respond with an ACK(1) message. The HSTU-C shall then initiate the clear-down procedure specified in § 11.3.

10.1.3 Transaction C

In Transaction C, capabilities are exchanged and negotiated by the two stations. Transaction C shall be followed by either a Transaction A or Transaction B during the same session to select a common mode of operation identified during the capabilities exchange.

10.2 Extended transactions

Table 14/G.994.1 shows the set of extended transactions specified in G.994.1. Each transaction is initiated by the HSTU-R and ends with an ACK(1). Extended transactions are derived from a concatenation of two basic transactions. They are used when the HSTU-C wishes to control the negotiation procedure. At the end of an extended G.994.1 transaction, the stations shall either terminate the G.994.1 session as specified in § 11.3, or shall go to the Initial HSTU-x Transaction state as shown in Figure 12/G.994.1 or Figure 13/G.994.1.

NOTE - The continuation of G.994.1 modulation after the conclusion of the G.994.1 session, for the purpose of implementing other protocols (for example G.997.1 - see Table 10/G.994.1), is for further study.

TABLE 14/G.994.1

Extended G.994.1 transactions

Transaction identifier	HSTU-R	HSTU-C	HSTU-R	HSTU-C	HSTU-R
A:B	MS →	REQ-MR →	MR →	MS →	ACK(1)
B:A	MR →	REQ-MS →	MS →	ACK(1)	
A:C	MS →	REQ-CLR →	CLR →	CL →	ACK(1)
B:C	MR →	REQ-CLR →	CLR →	CL →	ACK(1)

10.2.1 Transaction A:B

In Transaction A:B, the HSTU-R selects a mode of operation and requests that the HSTU-C transition to the selected mode. However, rather than responding to the MS message with an ACK(1) message as is the case for basic transaction A, the HSTU-C responds to the MS message with a REQ-MR message requesting the HSTU-R to proceed directly into basic transaction B without returning to the Initial Transaction state.

10.2.2 Transaction B:A

In Transaction B:A, the HSTU-R requests that the HSTU-C select the mode of operation. However, rather than responding to the MR message with an MS message as is the case for basic transaction B, the HSTU-C responds to the MR message with a REQ-MS message requesting the HSTU-R to proceed directly into basic transaction A without returning to the Initial Transaction state.

10.2.3 Transaction A:C

In Transaction A:C, the HSTU-R selects a mode of operation and requests that the HSTU-C transition to the selected mode. However, rather than responding to the MS message with an ACK(1) message as is the case for basic transaction A, the HSTU-C responds to the MS message with a REQ-CLR message requesting the HSTU-R to proceed directly into basic transaction C without returning to the Initial Transaction state.

10.2.4 Transaction B:C

In Transaction B:C, the HSTU-R requests that the HSTU-C select the mode of operation. However, rather than responding to the MR message with an MS message as is the case for basic transaction B, the HSTU-C responds to the MR message with a REQ-CLR message requesting the HSTU-R to proceed directly into a transaction C without returning to the Initial Transaction state.

10.3 Message segmentation

Not including the 2 octets of FCS and any octets that have been inserted to achieve octet transparency (see § 8.4), the maximum number of octets in any frame shall be 64. If the message exceeds this limit, the remainder of the message may be contained in subsequent frames. Whether or not the message exceeds 64 octets, it may be split into segments.

The receiving station shall parse the frame to determine if the message has been fully transmitted. If the message has not been fully transmitted, the receiving station may request transmission of the next segment by transmitting an ACK(2). Further segments shall only be sent in response to an ACK(2). Only CLR, CL, and MS messages may be segmented.

Where non-standard information is present in the message, the standard and non-standard information may be conveyed in separate frames.

10.4 State transition diagrams

Figure 12/G.994.1 and Figure 13/G.994.1 specify all permitted state transitions for the HSTU-R and HSTU-C stations respectively.

The state transition diagrams show state information (the state name and current transmitted message) and transition information (received message that caused the state change).

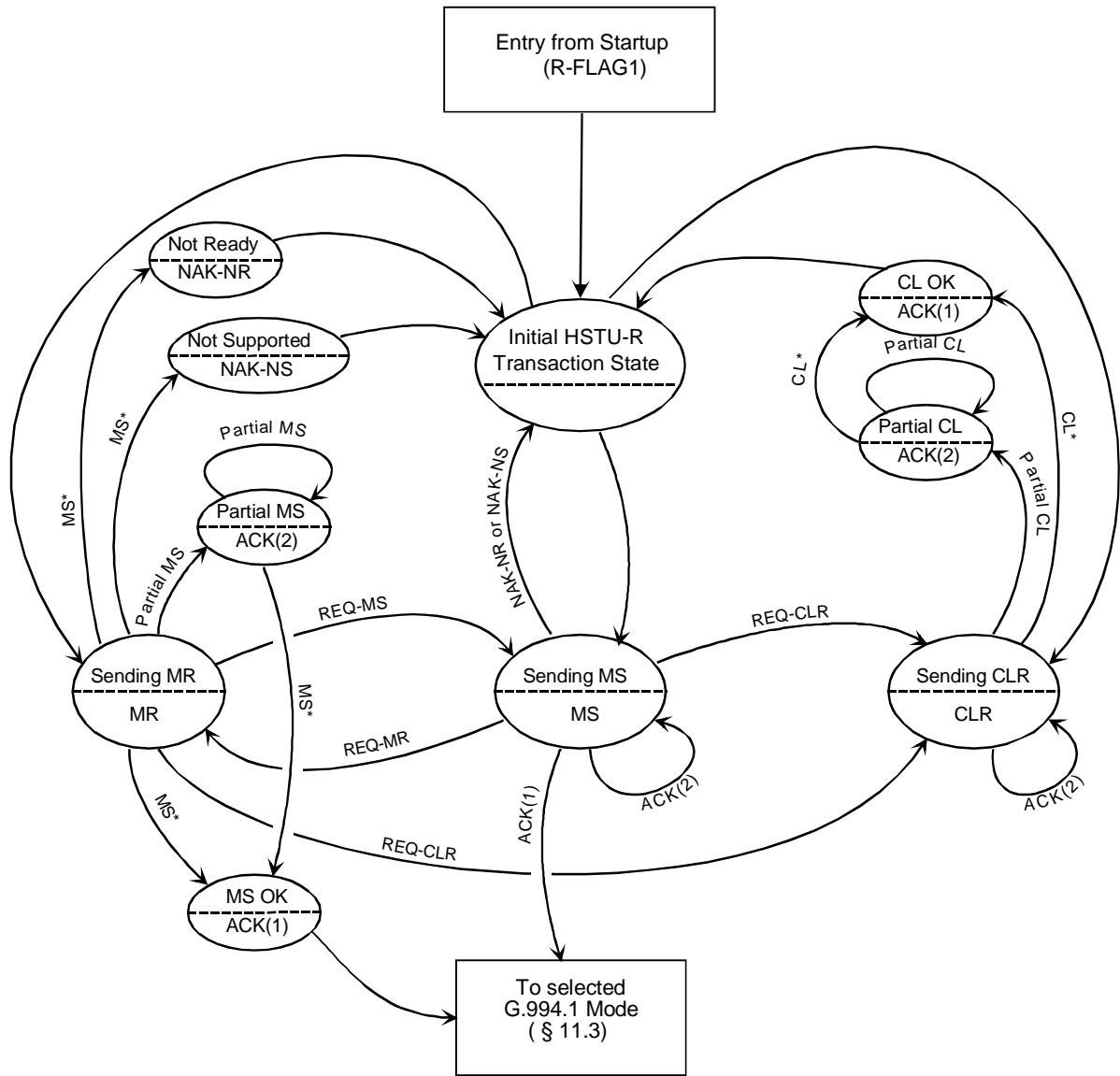

[Any State, including the Initial HSTU-R Transaction State] $\xrightarrow{\text{(errored frame)}}$ Restart NAK-EF \rightarrow To R-SILENT0, the Initial G.994.1 State for an HSTU-R (§ 12)

[Any State, except Not Supported, Not Ready, or Not Understood] $\xrightarrow{\text{(any not understood frame)}}$ Not Understood NAK-CD \rightarrow To Initial G.994.1 State (§ 11.3)

[Any State, except Not Supported, Not Ready, or Not Understood] $\xrightarrow{\text{NAK-CD}}$ \rightarrow To Initial G.994.1 State (§ 11.3)

NOTE: Message names followed by an asterisk (*) indicate that the state transition may be taken upon the reception of a complete message, or upon the reception of one or more segments of the message.

FIGURE 12/G.994.1
HSTU-R state transition diagram

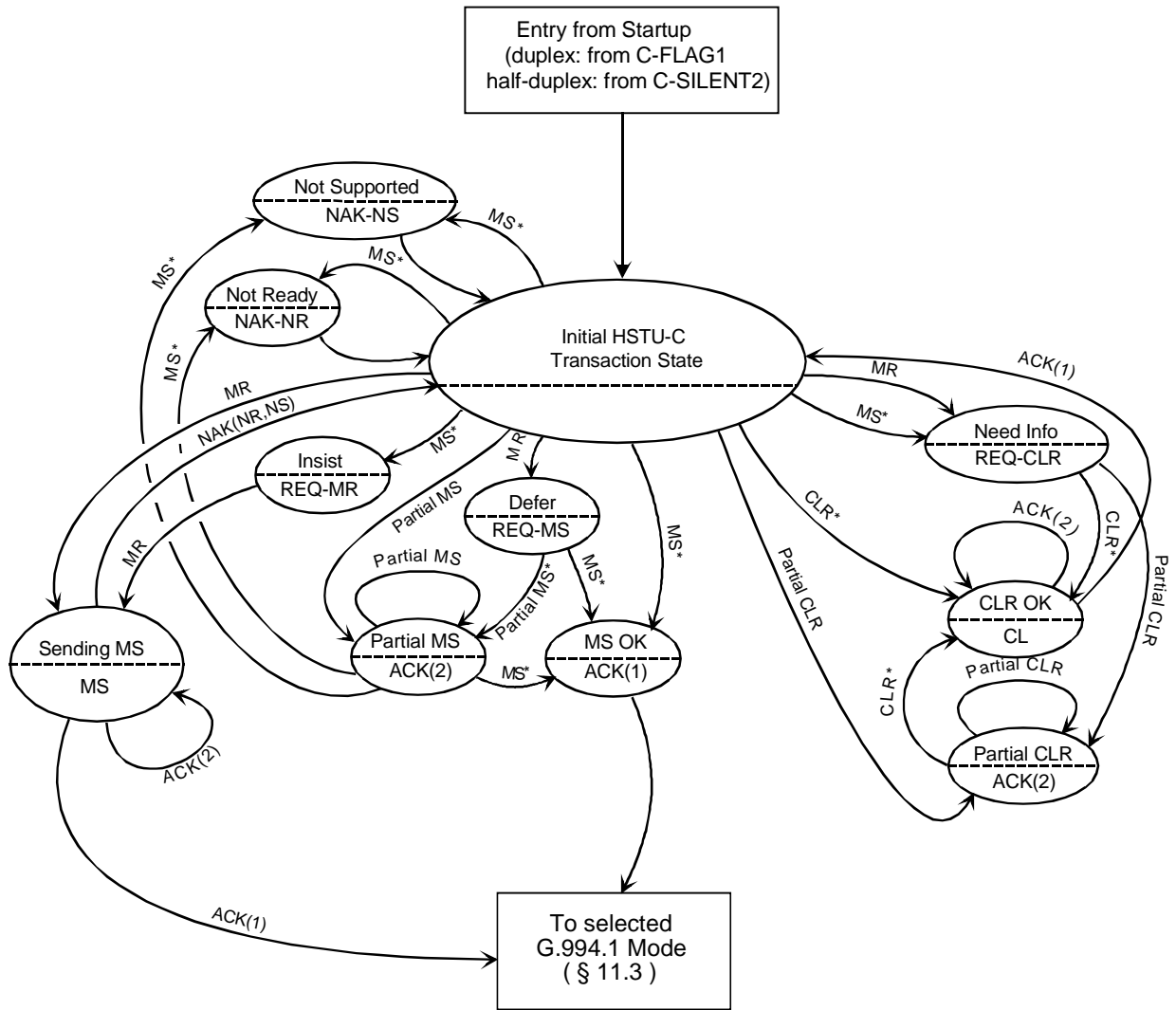

[Any State, including the Initial HSTU-C Transaction State] $\xrightarrow{\text{(errored frame)}}$ Restart (NAK-EF) \rightarrow To C-SILENT1, the Initial G.994.1 State for an HSTU-C (§ 12)

[Any State except Not Supported, Not Ready, or Not Understood] $\xrightarrow{\text{(any not understood frame)}}$ Not Understood (NAK-CD) \rightarrow To Initial G.994.1 State (§ 11.3)

[Any State except Not Supported, Not Ready, or Not Understood] $\xrightarrow{\text{NAK-CD}}$ To Initial G.994.1 State (§ 11.3)

NOTE: Message names followed by an asterisk (*) indicate that the state transition may be taken upon the reception of a complete message, or upon the reception of one or more segments of the message.

FIGURE 13/G.994.1
HSTU-C state transition diagram

Transmission of signals associated with a selected mode shall follow the transmission of ACK(1) and the G.994.1 clear-down procedure. The time delay between the end of a G.994.1 session and the start of the selected mode is specified in the associated Recommendation.

11 Start-up/clear-down procedures

11.1 Duplex start-up procedures

11.1.1 HSTU-R initiated start-up procedure

Figure 14/G.994.1 displays the timing for the HSTU-R initiated duplex start-up procedure. Initially, the HSTU-R is in state R-SILENT0 transmitting silence, and the HSTU-C is in state C-SILENT1 transmitting silence. The HSTU-R shall initiate the start-up procedure by transmitting signals from one or both of its signalling families, with phase reversals every 16 ms (R-TONES-REQ). When this has been detected by the HSTU-C, the HSTU-C shall respond by transmitting signals from one or both of its signalling families (C-TONES). When this has been detected by the HSTU-R, the HSTU-R shall transmit silence (R-SILENT1) for 50 to 500 ms and shall then transmit signals from only one signalling family (R-TONE1). The minimum detection time for C-TONES shall be 50 ms. When the HSTU-C has detected R-TONE1, it shall respond by transmitting Galfs on modulated carriers (C-GALF1). When the HSTU-R has detected Galfs, it shall respond by transmitting Flags on modulated carriers (R-FLAG1). When the HSTU-C has detected Flags, it shall respond by transmitting Flags (C-FLAG1). When the HSTU-R has detected Flags, it shall begin the first transaction.

Figure 14/G.994.1 shows the timing requirements between events that shall be adhered to. τ_1 is the time period from detection of a signal (e.g. R-TONE1) to the transmission of the next signal (e.g. C-GALF1).

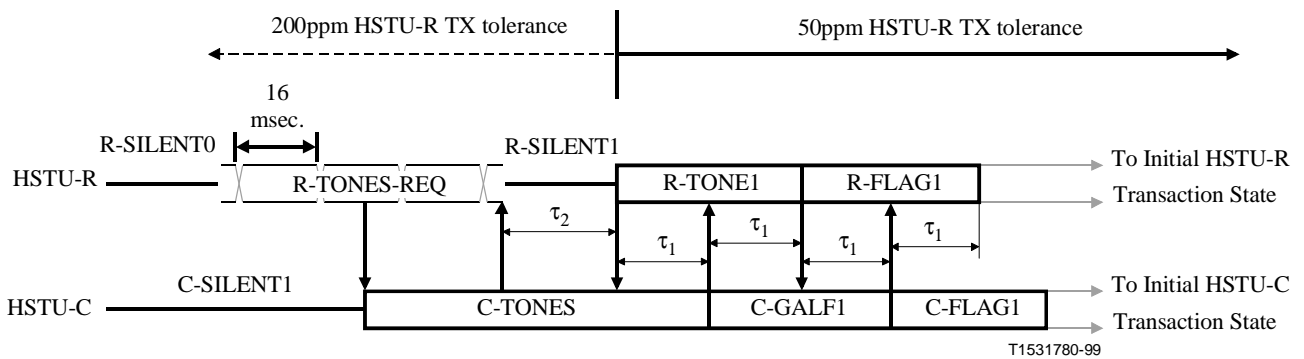

$$\tau_1 < 500 \text{ msec.}$$

$$50 \text{ msec.} < \tau_2 < 500 \text{ msec.}$$

FIGURE 14/G.994.1

HSTU-R initiated duplex start-up procedure

11.1.2 HSTU-C initiated start-up procedure

Figure 15/G.994.1 displays the timing for the HSTU-C initiated duplex start-up procedure. Initially, the HSTU-R is in state R-SILENT0 transmitting silence, and the HSTU-C is in state C-SILENT1 transmitting silence. The HSTU-C shall initiate the start-up procedure by transmitting signals from one or both of its signalling families (C-TONES). When this has been detected by the HSTU-R, the HSTU-R shall respond by transmitting signals from only one signalling family (R-TONE1). The minimum detection time for C-TONES shall be 50 ms. When the HSTU-C has detected R-TONE1, it shall respond by transmitting Galfs on modulated carriers (C-GALF1). When the HSTU-R has detected Galfs, it shall respond by transmitting Flags on modulated carriers (R-FLAG1). When the HSTU-C has detected Flags, it shall respond by transmitting Flags (C-FLAG1). When the HSTU-R has detected Flags, it shall begin the first transaction.

Figure 15/G.994.1 shows the timing requirements between events that shall be adhered to. τ_1 is the time period from detection of a signal (e.g. R-TONE1) to the transmission of the next signal (e.g. C-GALF1).

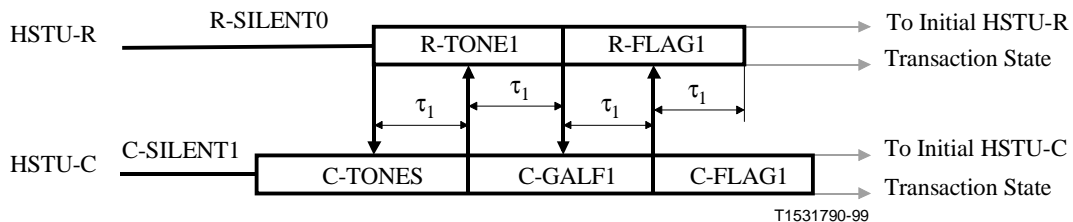

$$\tau_1 < 500 \text{ msec.}$$

FIGURE 15/G.994.1

HSTU-C initiated duplex start-up procedure

11.2 Half-duplex start-up procedures

11.2.1 HSTU-R initiated start-up procedure

Figure 16/G.994.1 displays the timing for the HSTU-R initiated half-duplex start-up procedure. Initially, the HSTU-R is in state R-SILENT0 transmitting silence, and the HSTU-C is in state C-SILENT1 transmitting silence. The HSTU-R shall initiate the start-up procedure by transmitting signals from one or both of its signalling families, with phase reversals every 16 ms (R-TONES-REQ). When this has been detected by the HSTU-C, the HSTU-C shall respond by transmitting signals from one or both of its signalling families (C-TONES). When this has been detected by the HSTU-R, the HSTU-R shall transmit silence (R-SILENT1) for 50 to 500 ms and shall then transmit flags modulated on carriers from only one signalling family (R-FLAG1). The minimum detection time for C-TONES shall be 50 ms. When the HSTU-C has detected R-FLAG1, it shall respond by transmitting silence. When the HSTU-R has detected the silence, it shall continue to transmit Flags for period τ_1 and shall then begin the first transaction.

Figure 16/G.994.1 shows the timing requirements between events that shall be adhered to. τ_1 is the time period from detection of a signal (e.g. R-TONE1) to the transmission of the next signal (e.g. C-GALF1).

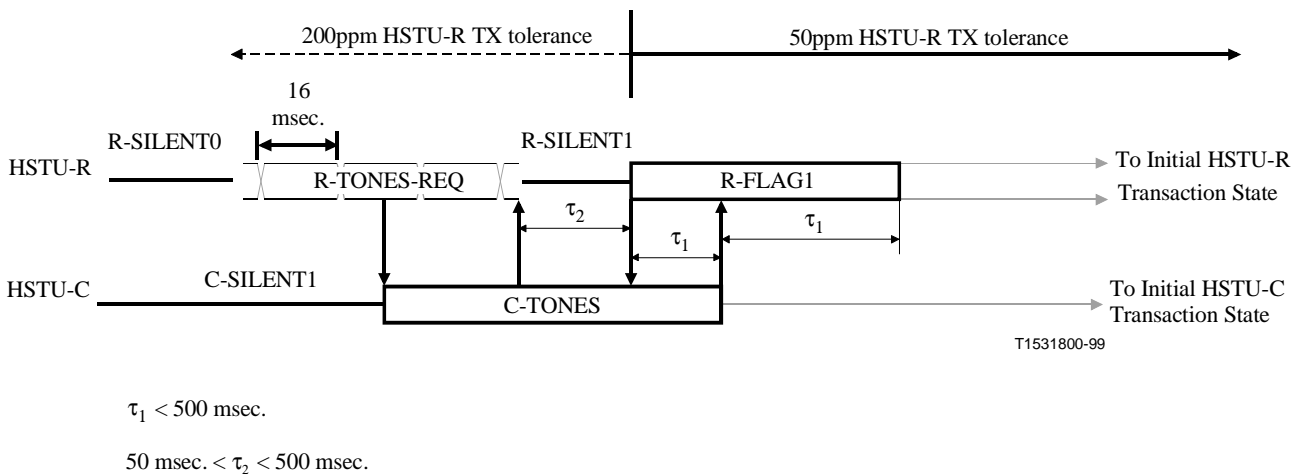

FIGURE 16/G.994.1

HSTU-R initiated half-duplex start-up procedure

11.2.2 HSTU-C initiated start-up procedure

Figure 17/G.994.1 displays the timing for the HSTU-C initiated half-duplex start-up procedure. Initially, the HSTU-R is in state R-SILENT0 transmitting silence, and the HSTU-C is in state C-SILENT1 transmitting silence. The HSTU-C shall initiate the start-up procedure by transmitting signals from one or both of its signalling families (C-TONES). When this has been detected by the HSTU-R, the HSTU-R shall respond by transmitting flags modulated on carriers from only one signalling family (R-FLAG1). The minimum detection time for C-TONES shall be 50 ms. When the HSTU-C has detected R-FLAG1, it shall respond by transmitting silence. When the HSTU-R has detected the silence, it shall continue to transmit Flags for period τ_1 and shall then begin the first transaction.

Figure 17/G.994.1 shows the timing requirements between events that shall be adhered to. τ_1 is the time period from detection of a signal (e.g. R-TONE1) to the transmission of the next signal (e.g. C-GALF1).

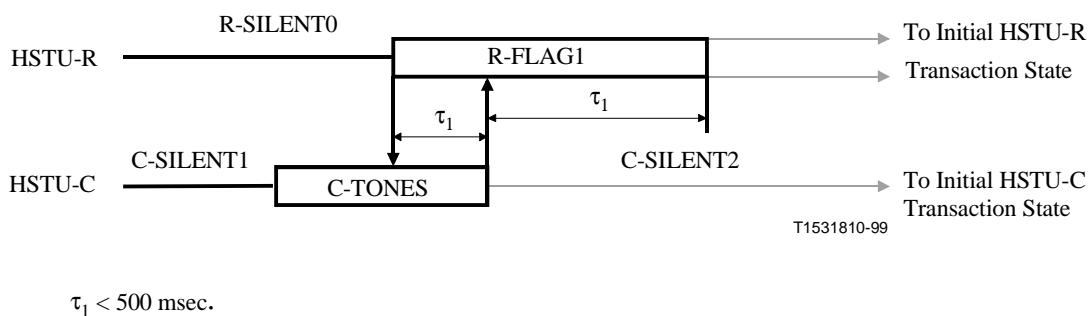

FIGURE 17/G.994.1

HSTU-C initiated half-duplex start-up procedure

11.3 Cleardown procedure

Figure 18/G.994.1 displays the timing for cleardown of a duplex G.994.1 session (by either the HSTU-R or the HSTU-C). When an HSTU-R (HSTU-C) receives an ACK(1) message in response to an MS message, or receives a NAK-CD message, it shall initiate the cleardown procedure. After receiving the ACK(1) or NAK-CD message, the HSTU-R (HSTU-C) shall continue to transmit Flags for a period not to exceed 0.5 seconds. It shall then transmit 4 octets of Galf (referred to as R-GALF2 for an HSTU-R, C-GALF2 for an HSTU-C), followed by silence which terminates the G.994.1 session. When the HSTU-C (HSTU-R) detects either Galfs or silence, it shall continue to transmit Flags (referred to as C-FLAG2 for an HSTU-C, R-FLAG2 for an HSTU-R) for a period not to exceed 0.5 seconds, followed by silence which terminates the G.994.1 session.

If a received MS message indicates a common operating mode, both stations shall transition to the selected mode upon termination of the G.994.1 session. If a received MS message indicates that there is no common operating mode (see § 10.1), or the cleardown was initiated by a NAK-CD, both stations shall return to the initial G.994.1 state (R-SILENT0 for an HSTU-R, C-SILENT1 for an HSTU-C).

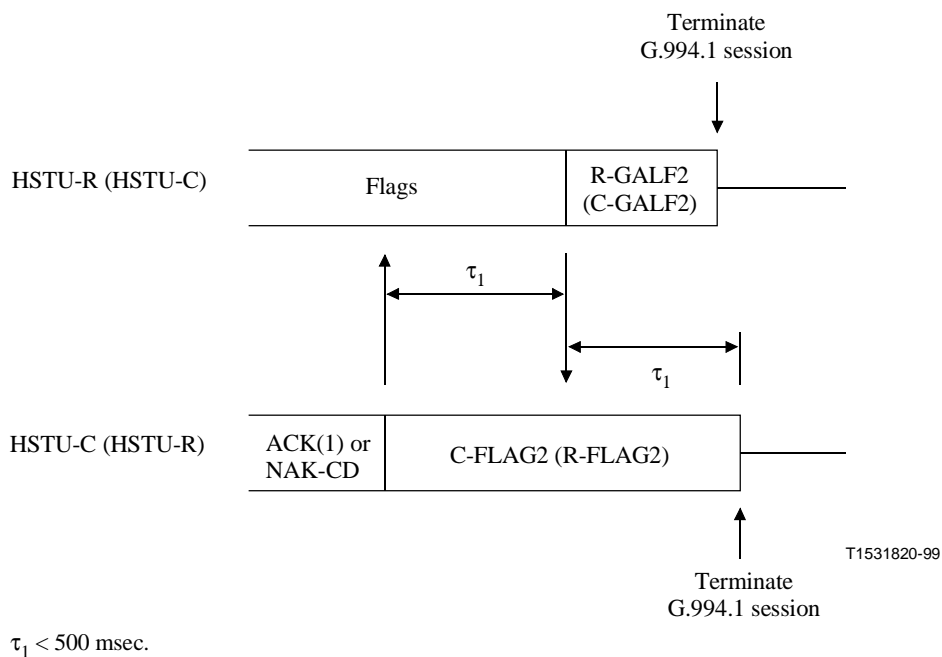

FIGURE 18/G.994.1

Duplex cleardown procedure

Figure 19/G.994.1 displays the timing for cleardown of a half-duplex G.994.1 session (by either the HSTU-R or the HSTU-C). When an HSTU-R (HSTU-C) receives an ACK(1) message in response to an MS message, or receives a NAK-CD message, it shall initiate the cleardown procedure.

After receiving the ACK(1) or NAK-CD message, the HSTU-R (HSTU-C) shall continue to transmit silence for a period not to exceed 0.5 seconds. It shall then transmit 4 octets of Galf (referred to as R-GALF2 for an HSTU-R, C-GALF2 for an HSTU-C), followed by silence which terminates the G.994.1 session.

When the HSTU-C (HSTU-R) detects either Galfs or continued silence after a timeout of 0.5 seconds, it shall continue to transmit silence for a period not to exceed 0.5 seconds and then terminate the G.994.1 session.

If a received MS message indicates a common operating mode, both stations shall transition to the selected mode upon termination of the G.994.1 session. If a received MS message indicates that there is no common operating mode (see § 10.1), or a clear-down was initiated by a NAK-CD, both stations shall return to the initial G.994.1 state (R-SILENT0 for an HSTU-R, C-SILENT1 for an HSTU-C).

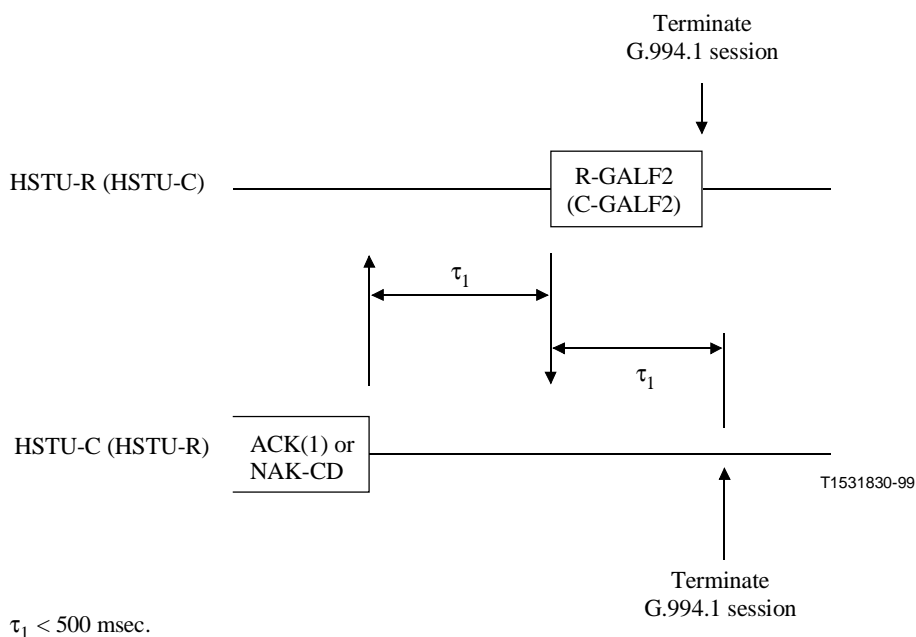

FIGURE 19/G.994.1

Half-duplex clear-down procedure

12 Error recovery procedures

The timing requirements used for error recovery during the start-up procedure of a G.994.1 session are specified in Figure 14/G.994.1 through Figure 17/G.994.1.

During a G.994.1 session, the maximum time between the reception of the end of any frame and the start of transmission of the next frame shall be 0.5 seconds.

During a G.994.1 session, for transactions where the HSTU-R transmits the final message, the maximum time between the end of transmission of the final frame of the transaction and the start of transmission of the first frame of the next transaction shall be 0.5 seconds.

If either station times out, it shall immediately return to the initial G.994.1 state (R-SILENT0 for an HSTU-R, C-SILENT1 for an HSTU-C) and remain silent for a minimum period of 0.5 seconds. It may then initiate another G.994.1 session.

If an errored frame is received in any state (including the Initial HSTU-x Transaction State), the receiving station shall abort the G.994.1 session by sending a NAK-EF message. It shall then return immediately to the initial G.994.1 state (R-SILENT0 for an HSTU-R, C-SILENT1 for an HSTU-C) and remain silent for a minimum period of 0.5 seconds. It may then initiate another G.994.1 session.

If a NAK-EF message is received in any state, the receiving station shall return immediately to the initial G.994.1 state (R-SILENT0 for an HSTU-R, C-SILENT1 for an HSTU-C) and remain silent for a minimum period of 0.5 seconds. It may then initiate another G.994.1 session.

If an invalid frame is received in any state, it shall be ignored.

ANNEX A

Support for Non-G.994.1 Devices

Systems that support interoperability with non-G.994.1 compliant devices shall perform the following procedure at initialization:

The HSTU-R shall alternately attempt G.994.1 and other non-G.994.1 initialization as follows:

- transmit R-TONES-REQ for 2 seconds
- transmit silence for 100 ms
- transmit other non-G.994.1 initiating signal for 2 seconds
- transmit silence for 100 ms
- repeat above (starting with R-TONES-REQ)

Manufacturers are encouraged to implement multimode systems to cover this interoperability issue.

NOTE - Future handshake protocols may modify the sequence described in this annex. Implementations are encouraged to tolerate such differences.

APPENDIX I

G.994.1 sample sessions

Session	msg 1	msg 2	msg 3	msg 4	msg 5	msg 6	msg 7	msg 8
1	CLR	cl	ACK(1)	MS	ack(1)			
2	MS	ack(1)						
3	MS	req-mr	MR	ms	ACK(1)			
4	MS	req-clr	CLR	cl	ACK(1)	MS	ack(1)	
5	CLR	cl	ACK(1)	MR	ms	ACK(1)		
6	MR	ms	ACK(1)					
7	MR	req-ms	MS	ack(1)				
8	MR	req-clr	CLR	cl	ACK(1)	MR	ms	ACK(1)

NOTE - HSTU-R transmitted messages are shown in uppercase, whilst HSTU-C transmitted messages are shown in lowercase.

APPENDIX II

Provider code contact information

It is often difficult for implementers to find information about obtaining provider codes since they are regional and not specified in Recommendation T.35. This appendix contains information about obtaining provider codes.

Country	Relevant document	Contact telephone	Contact information
USA	T1.220	+1 732 699 5577	Telcordia's Language Standards Department 444 Hoes Lane, Piscataway NJ 08854 USA
Japan	-	+81 3 3432 1551	TTC, 1-2-11, Hamamatsu-cho, Minato-ku, Tokyo 105-0013, Japan
Belgium	-	Tel. (+32) 2 226 88 99 Fax. (+32) 2 223 11 28	Belgian Institute of postal services and telecommunications Avenue de l'Astronomie, 14 Boîte 21 1210 Brussels, Belgium

APPENDIX III

Support for Legacy DMT-Based Devices

Systems that support interoperability with [1] should perform the following functions at initialization:

- the HSTU-C should monitor for R-ACK-REQ (as defined in [1])
- the HSTU-R should monitor for C-ACT1, C-ACT2, C-ACT3, C-ACT4, and C-TONE (as defined in [1])
- the HSTU-R should alternately attempt initiating signals from G.994.1 and [1] as follows:
 - transmit R-TONES-REQ for 2 seconds
 - transmit silence for 100 ms
 - transmit R-ACK-REQ for 2 seconds
 - transmit silence for 100 ms
 - repeat above (starting with R-TONES-REQ)

Upon detection of the above tones, the system that supports interoperability with [1] should follow the procedures and functions described therein.

APPENDIX IV

Procedure for the Assignment of Additional G.994.1 Parameters

IV.1 Introduction

This Appendix defines the procedure for requesting the assignment of G.994.1 parameters that are indicated as being “Reserved for allocation by the ITU-T.” This procedure is intended to allow for the expedient assignment of such parameters.

This procedure does not cover requests for changes to the category octets (which requires approval by SG15 at a Study Group meeting), or changes to the overall structure of G.994.1 (which requires application of the ITU-T Resolution 1 procedures).

IV.2 Procedure

An ITU-T Working Party or Study Group that identifies a need for the assignment of a G.994.1 parameter is required to make that request to the Chairman of Study Group 15 with copies of the request to the editor of G.994.1 and the TSB councillor for SG15. After consultation with the editor of G.994.1, the Chairman will either approve the request or provide an alternative solution to the request (if a change is necessary to achieve compliance with G.994.1). Periodically, these allocated parameters will be included in the G.994.1 Implementors Guide, which will finally be merged into a subsequent revision of the Recommendation.

It is expected that requests using this procedure will obtain a response within one month.

APPENDIX V

Bibliography

- [1] ANSI T1.413 – 1998, Network and Customer Installation Interfaces – Asymmetric Digital Subscriber Line (ADSL) Metallic Interface.
-